

## 20-0170 Testing cooling system for leaks

Operation no. of operation texts and work units or standard texts  
and flat rates:  
20-1010

### Special tools

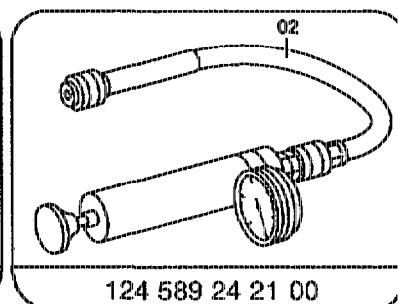
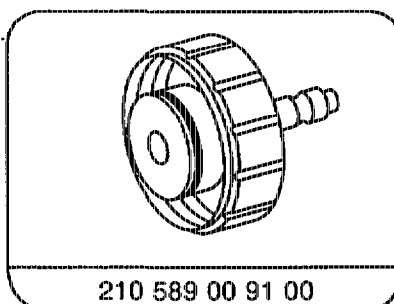
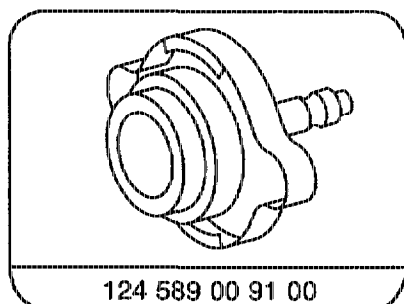

### Commercially available tools and testers

| Designation   | e. g. | make, order no.                              |
|---|-------|--|
| 7 mm socket wrench hexagon on flexible shaft for hose clips with worm drive |       | Hazet,<br>42853 Remscheid<br>Order no. 426-7 |



The cylinder head gasket is not watertight until the engine has reached operating temperature, in other words until a swelling operation has taken place. For this reason, the cooling system must be pressure-tested until after the engine has reached operating temperature.

### Testing system for leaks

1 Turn cap as far as detent 1 and release pressure, then turn on as far as detent 2 and remove cap.  
Open 2-stage cap half a turn to release pressure and then unscrew.

2 Take off cap.

### Note

The cap must not be opened unless the coolant temperature is below 90 °C.  
A 2-stage cap is installed in model 210; see note.

3 Check coolant level and adjust to correct level.

**Note**

Model 124: pour in coolant up to the marking on the expansion reservoir.

Models 129, 140, 202: pour in coolant up to the separation line between top part of expansion reservoir (black) and bottom part of reservoir (transparent).

Model 210: pour in coolant up to the marking (cast lug) on the bottom of the expansion reservoir.

4 Pressurize cooling system to about 1.4 bar with the test cap and the tester.

5 Examine all the cooling and heating water hoses and their connection points for loss of coolant.

6 Check condition of coolant hoses and hose clips; replace or re-tighten if necessary.

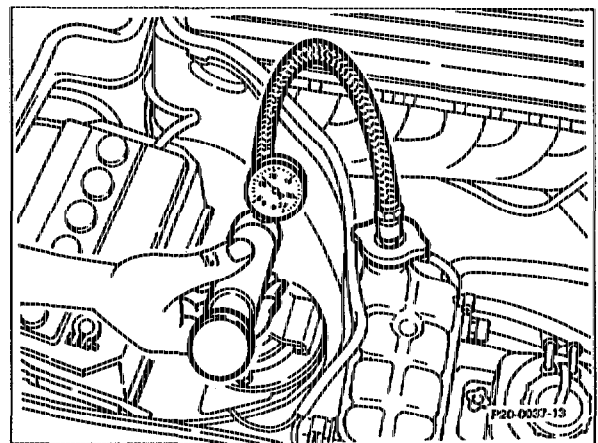

**Note**

A 2-stage cap is installed in the expansion reservoir of model 210.

The 2-stage cap eliminates the need for the overflow reservoir.

The pressure in the cooling system may rise during the engine off heating phase (after switching off engine).

The first stage in the coolant cap opens at 1.4 bar; the cooling system remains closed, however.

It is only if the 2nd stage in the coolant cap opens (at 2.0 bar) that coolant flows out to atmosphere along several vent drillings (a), the ring duct (b) into the outlet connection (c) and along a hose extension.

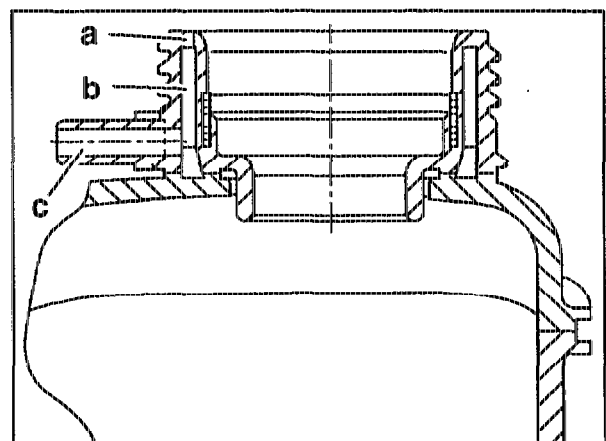

P20-5407-13