

# Brakes from CLK (C209) and SLK55 AMG (R171)

Front calipers:	A003 420 47 83 / A003 420 67 83	RH	208 88 503 (1A) (marked on calipers)
AMG 6-piston	A003 420 48 83 / A003 420 68 83	LH	208 88 504(1A) (marked on calipers)

Rear calipers:		RH	208 64 301 (marked on calipers)
AMG 4-piston		LH	208 64 303 (marked on calipers)

2-piece discs front:	A209 421 01 12
AMG 360 x 32 mm	

1-piece discs rear:	A230 423 09 12
330 x 26 mm	

## Components for front calipers

Mounting brackets:

340 x 32mm discs	000 420 76 15 comes up on	19.7661-07 (AMG bracket marking)
360 x 32mm discs	both caliper types. kr.2.072,-	19.7661-08 (AMG bracket marking)

Mounting bolts:

M12 x 1,5 x 35 mm	124 421 05 71	(2 per caliper)
-------------------	---------------	-----------------

M12 x 1,5 x 45 mm	124 421 04 71	(2 per caliper)
-------------------	---------------	-----------------

Sliding bolts:	209 421 00 14	(1 per caliper)
----------------	---------------	-----------------

	016 990 06 01	(1 per caliper)
--	---------------	-----------------

Locking pins:	000 421 36 74	(2 per caliper)
---------------	---------------	-----------------

Locking plates:	000 421 92 91	(1 per caliper)
-----------------	---------------	-----------------

Pad sensors:

Brake pads:

# 6-piston AMG calipers for 340mm versus 360mm rotors

Mounting bracket for 340 x 32mm  
PN 000 420 76 15  
AMG number 19.7661-**07**

Mounting bracket for 360 x 32mm  
PN ???  
AMG number 19.7661-**08**



# 6-piston AMG caliper radial displacement

Caliper mounting bracket

10mm spacers with centering steps

Caliper housing

Extended assembling bolts

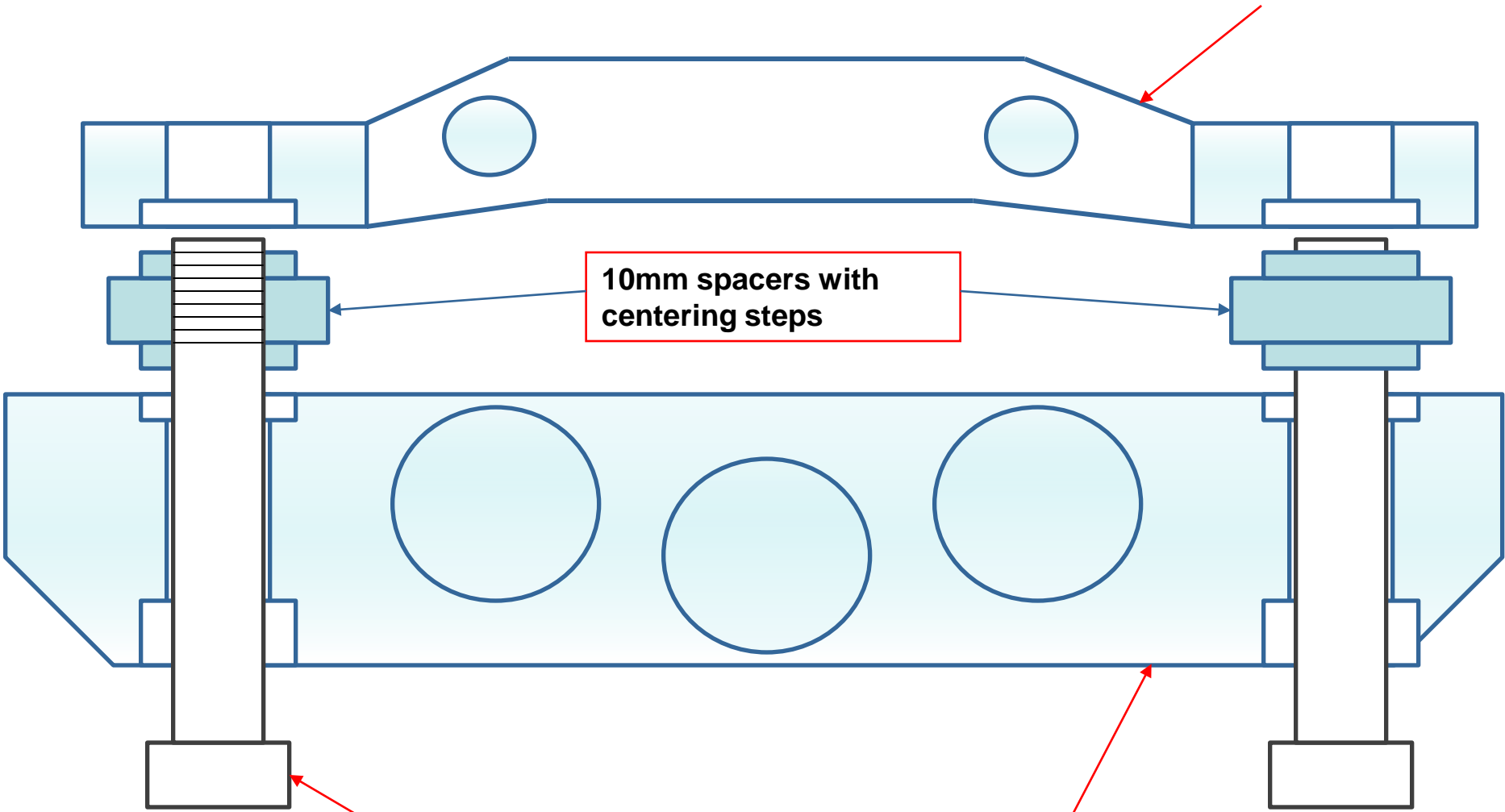

## Weight comparison front brakes

AMG 8-piston caliper	6.080 gr.
Pads	1.630 gr.
<u>360 x 36 mm disc</u>	<u>15.520 gr.</u>
	23.230 gr. per side
AMG 6-piston caliper	4.810 gr.
Pads	1.490 gr.
<u>360 x 32 mm disc</u>	<u>10.660 gr.</u>
	16.960 gr. per side
AMG 8-piston set versus 6-piston set:	6.270 gr. more per side
The disc represents :	4.860 gr. equals 78% of the weight increase

---

MOV'IT 370 x 35 mm, disc only	13.000 gr. each
-------------------------------	-----------------

---

StopTech 355 x 32 mm disc incl. 4/6-pot? Calipers and pads	13.600 gr. per side
---	---------------------