

Operation number of the operation texts and work units or standard texts and flat rates:  
27-1280

**A. Models 124 without 4MATIC, 126, 129, 140**

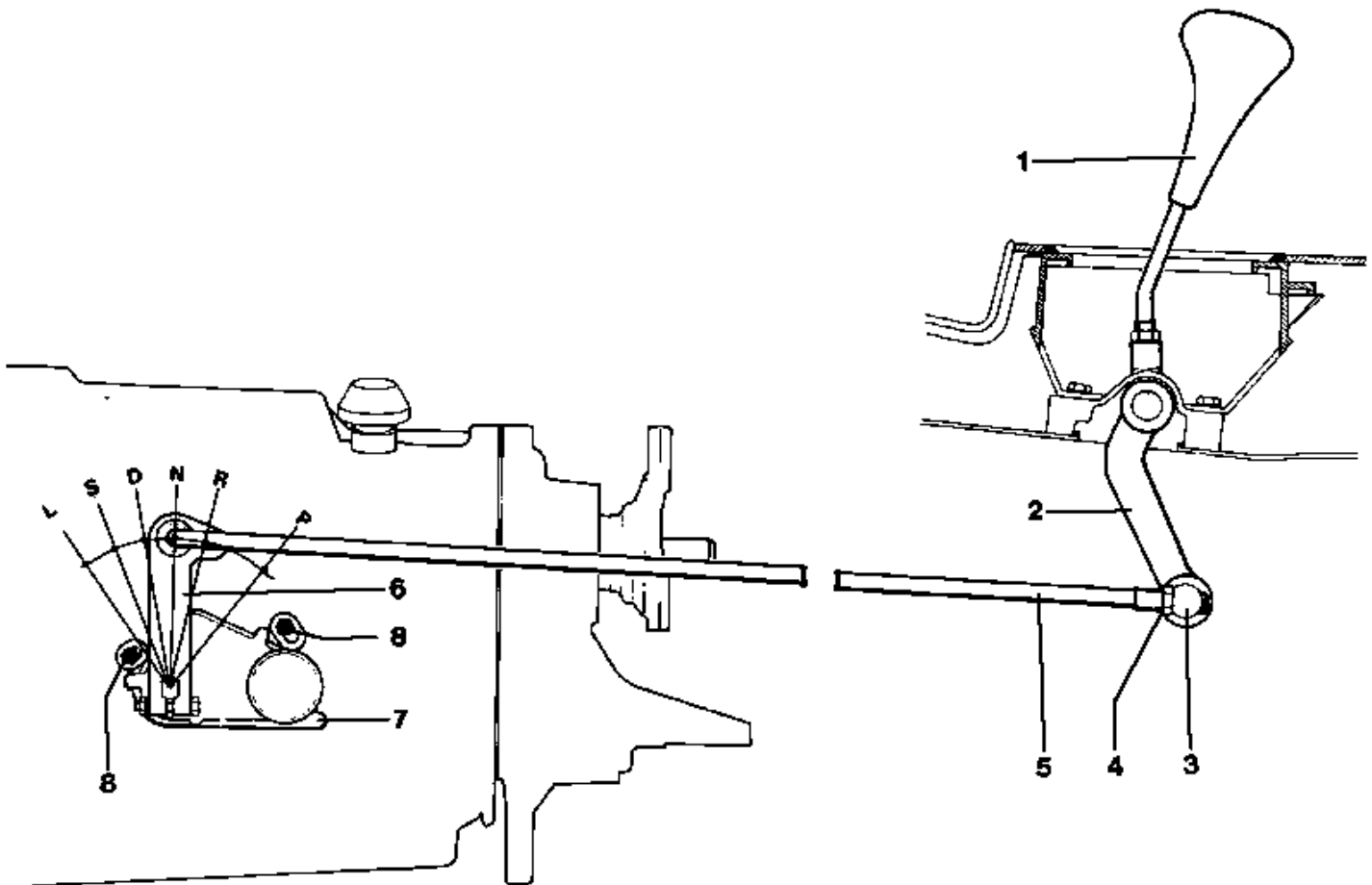

P27-5312-57

- |                               |  |
|-------------------------------|--|
|                               | <b>Note</b>  |
|                               | Park vehicle on a level surface  |
| Shift rod (5).....            | Unhook at selector lever (2).  |
| Range selector lever (6)..... | Move to position "N".  |
| Lock nut (4).....             | Slacken.   |
| Shift rod (5).....            | Adjust length so that there is approx. 1 mm clearance between the selector lever (1) and the "N" stop on the shift gate. |
| Shift rod (5).....            | Hook up.   |
| Lock nut (4).....             | Tighten securely.  |