

# 15-0520 Adapting ignition timing point with resistance trimming plug to available fuel

## A. Location of EZL resistance trimming plugs

### a) Basic version and (CH) KAT, (S) KAT EZL resistance trimming plug (R16)

#### Model 107

The EZL resistance trimming plug (R16) is located next to the diagnostic socket (X11) at the front left wheelhouse.

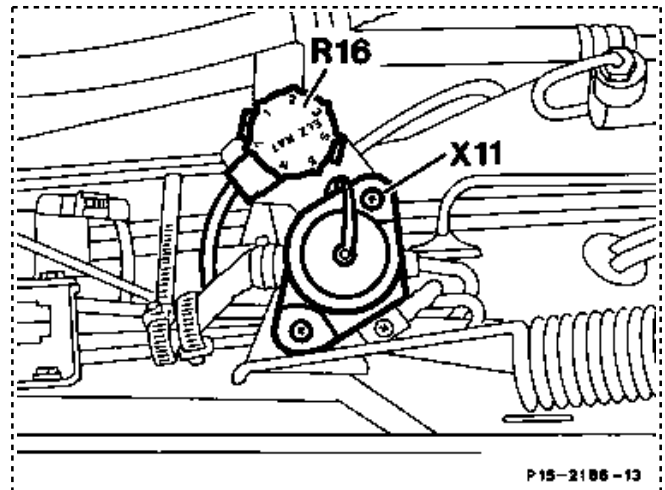

#### Model 124

The EZL resistance trimming plug (R16) is located on the left partition wall to the component compartment.

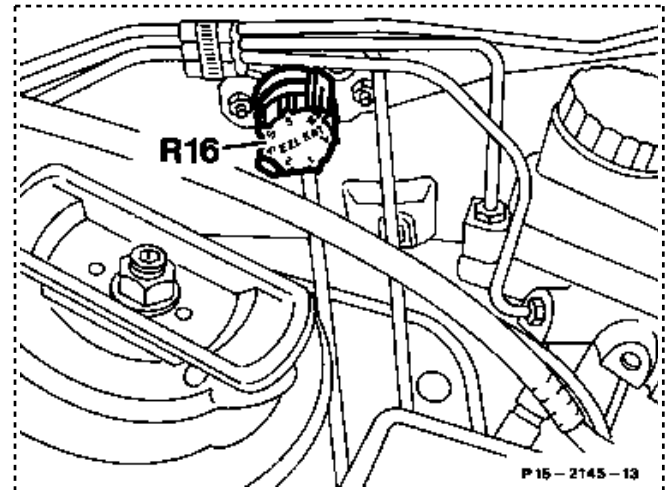

#### Model 124 with engine 103.980

The EZL resistance trimming plug (R16) is located in the right component compartment behind the battery.

- R16 EZL resistance trimming plug
- R17 KE resistance trimming plug

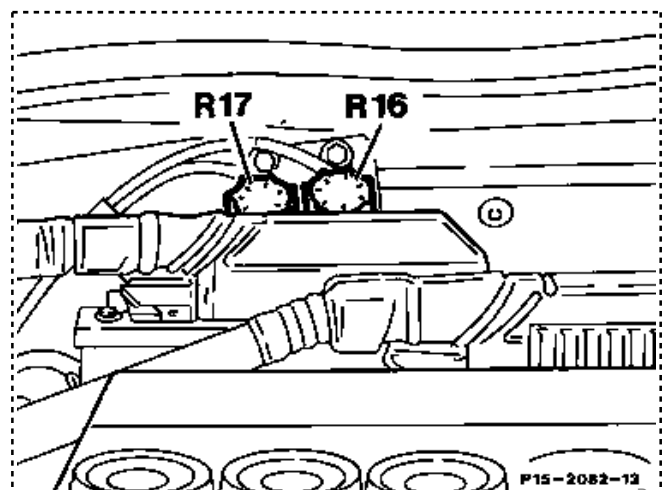

### Model 126

The EZL resistance trimming plug (R16) is located next to the interior/engine plug connection (X26) behind the fuse and relay box.

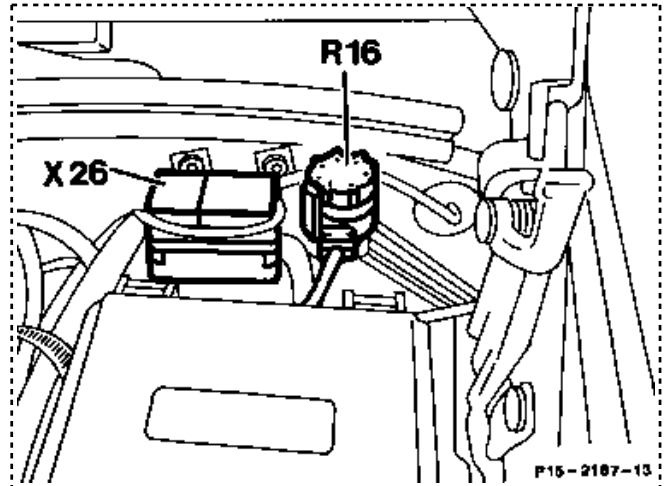

### Model 129

The EZL resistance trimming plug (R16) is located in the left of the component compartment.

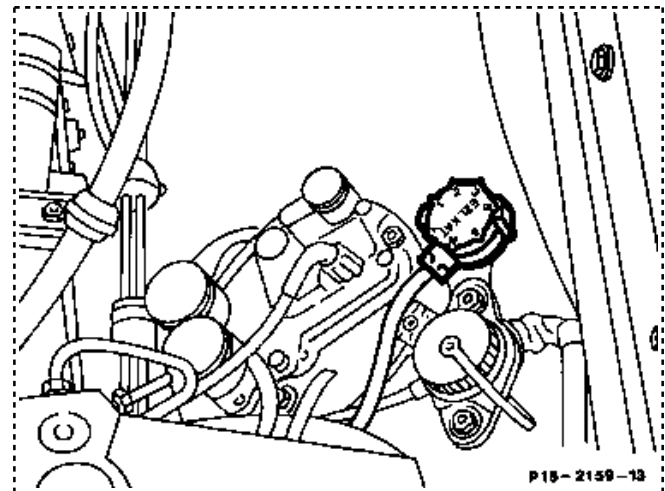

### Model 201

The EZL resistance trimming plug (R16) is located on the left wheelhouse next to the EZL ignition control unit.

## b) National version EZL reference resistor (R16/1)

### Model 124

The EZL reference resistor (R16/1) is located in the left component compartment close to the brake booster.

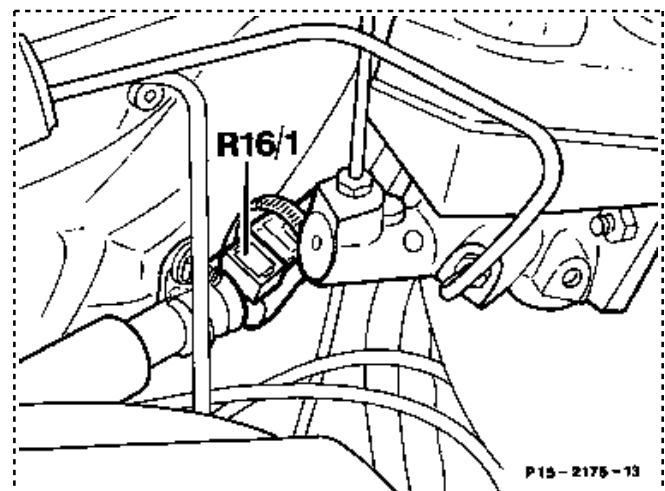

### Model 126

The EZL reference resistor (R16/1) is connected to the wiring harness between the fuse and relay box and the brake booster.

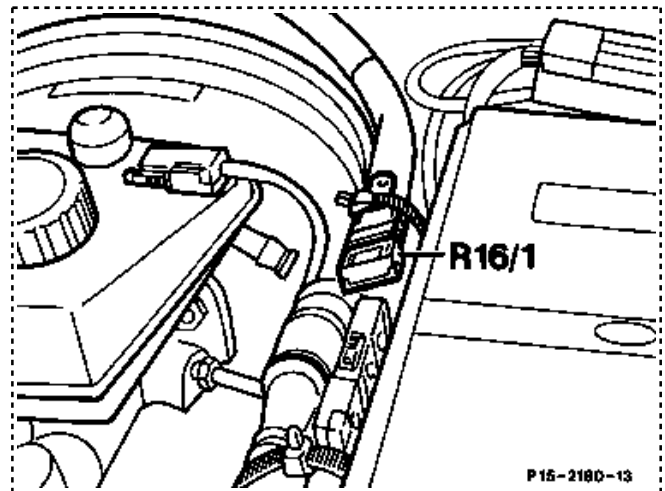

### Model 201

The EZL reference resistor (R16/1) is connected to the engine wiring harness close to the start valve.

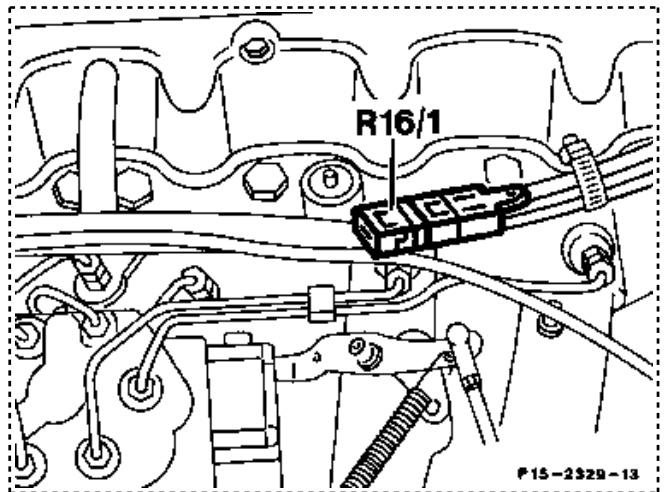

## B. Adapting ignition timing point with EZL reference resistor to fuel

To adjust, pull out resistance trimming plug as far as the stop, turn to the appropriate position and push in again.

### a) Vehicles in RÜF version with EZL resistance trimming plug, colour code white

These vehicles can be operated with leaded/unleaded premium fuel and leaded/unleaded regular fuel.

### Position "S"

Ignition timing point for leaded and unleaded premium fuel.

Position "4" corresponds to "S."

### Note

When operating the vehicles in Indonesia, it is necessary to adapt the ignition timing point by turning the resistance trimming plug to position "N" because of the reduced fuel quality with an RON of 92.

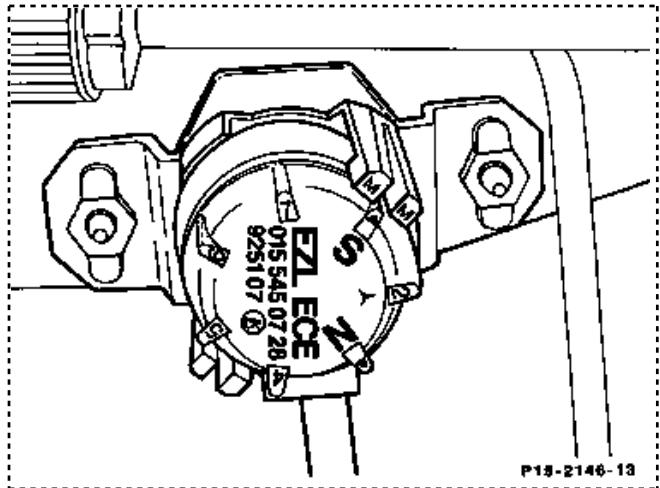

### Position "N"

Ignition timing point for leaded and unleaded regular fuel.

Position "6" corresponds to "N."

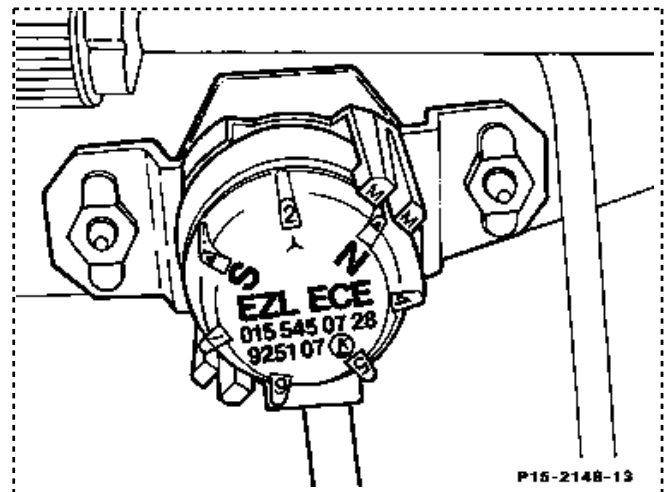

### Correction position for workshop

#### Position "2" - "premium" correction

Correction position by retarding ignition timing point 3° if only poor premium available (RON 92).

Position "5" corresponds to "2."

#### Position "7" - "regular" correction

Correction position by retarding ignition timing point 9° if only poor, unleaded regular fuel available (RON 89).

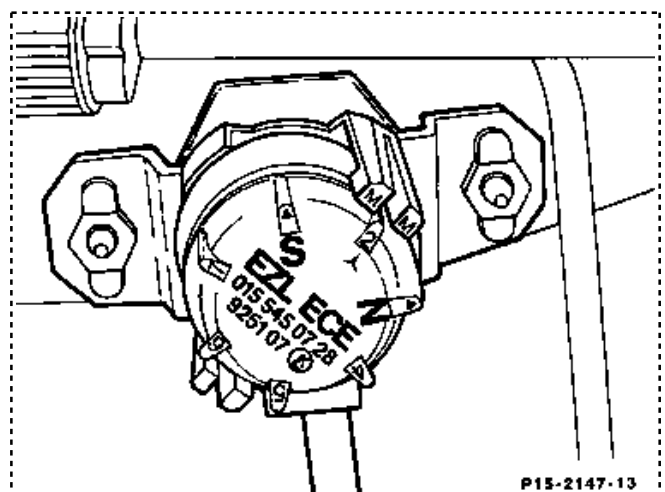

**b) Vehicles in KAT version with EZL-KAT resistance trimming plug, colour code green**



These vehicles may **only** be operated with **unleaded premium** or **unleaded regular** fuel.

**Position "S"**

Ignition timing point for unleaded premium fuel.

**Note**

When operating the vehicles in Indonesia, it is necessary to adapt the ignition timing point by turning the resistance trimming plug to position "N" because of the reduced fuel quality with an RON of 92.

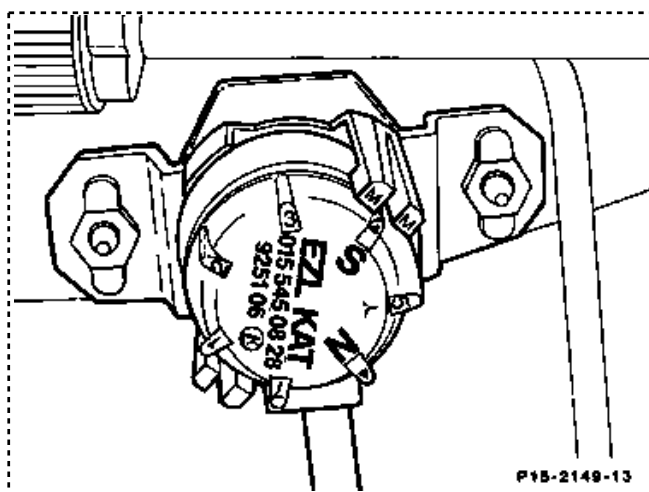

**Position "N"**

Ignition timing point for unleaded regular fuel. Position "3" corresponds to "N."

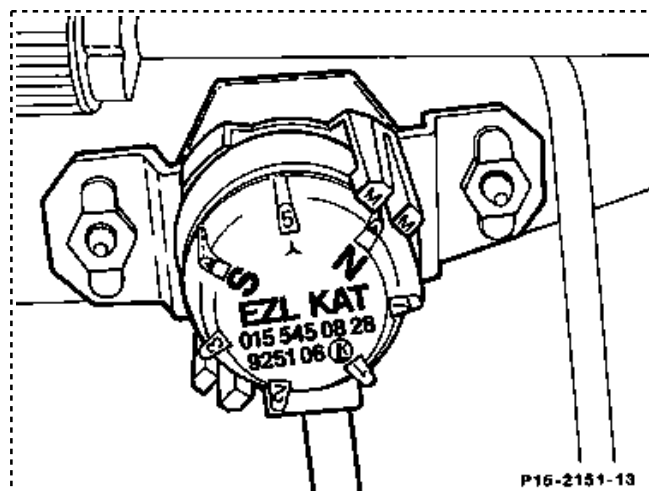

## Correction position for workshop

### Position "5" - "premium" correction

Correction position by retarding ignition timing point 3° if only poor, unleaded premium available (RON 92).

### Position "7" - "regular" correction

Correction position by retarding ignition timing point 9° if only poor, unleaded regular fuel available (RON 89).

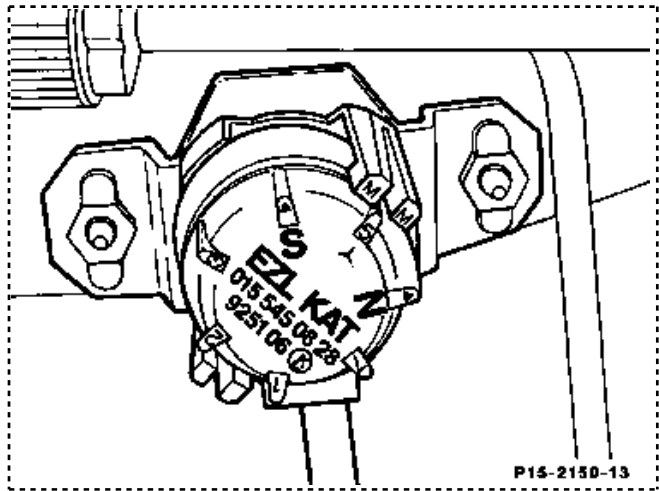

## c) Vehicles with engine 103.980 with ECE resistance trimming plug, colour code white



These vehicles may **only be operated with leaded/unleaded premium fuel.**

If only poor premium fuel is available, the ignition timing point can be retarded 2 ° CA per plug position.

### Position "1"

Ignition timing point for leaded premium fuel or unleaded "premium plus" fuel (RON 98).

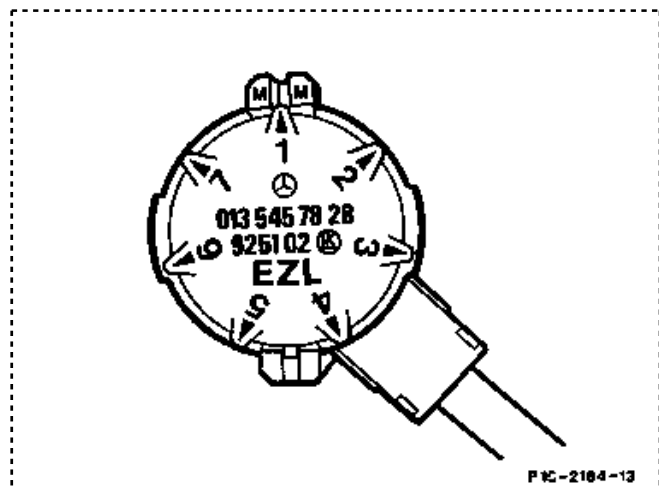

**Position "3"**

Ignition timing point for unleaded premium fuel (RON 95).

