

Installation Instructions

**Conversion to 225/45 ZR 17 tires and
7 1/2 J × 17 H 2 ET 42 disk wheel****40.30****Model 124**

Excluding vehicles with special protection, special bodywork, sedans with long wheelbase and 124.036.

All the work described in sections A, B and C must be carried out in full before the wheel/tire combination may be used.

The installation instructions are divided up into the following sections:

- A. Detaching the standard wheels
- B. Modifications to the chassis
- C. Modifications to the body
- D. Fitting the special wheels
- E. Tire inflation pressure/tire makes/using snow chains
- F. Technical details
- G. Information for ordering replacement parts

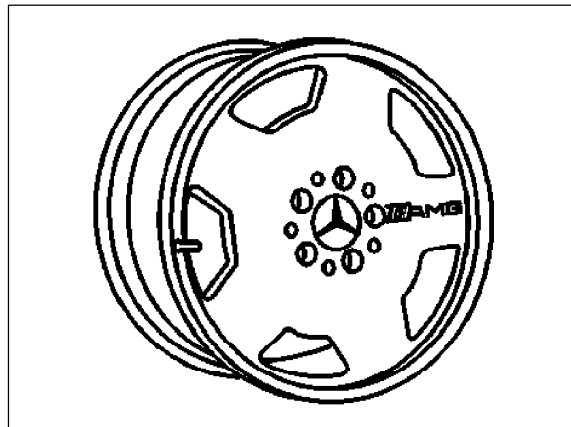

P40-5444-13

H WA124 401 03 02

Note

An entry in the vehicle documents is required in the Federal Republic of Germany. For this a copy of the respective sample report must be submitted to the TÜV/TÜA.

A. Detaching the standard wheels

- 1 Remove wheel covers on steel disk wheels.
- 2 Slacken wheel bolts.
- 3 Raise vehicle.
- 4 Unscrew wheel bolts.

Note

When unscrewing the final wheel bolt be sure that the wheel does not suddenly tilt off the hub.

- 5 Remove wheel.

M

Five of the standard wheel bolts removed must be retained for the spare wheel. The standard production spare wheel can be used as a temporary spare wheel.

A maximum speed of 80 km/h only is permissible due to the change in handling characteristics resulting from different tire rolling circumferences and wheel offsets. For this purpose, the standard production spare wheel is to be identified with the enclosed auxiliary sticker (H WA201 584 04 39). Replace the temporary spare wheel with a standard wheel as soon as possible.

B. Modifications to the chassis

In conjunction with 17-inch AMG disk wheels, the front axle compression travel on all vehicle models must be reduced in order to ensure adequate clearance under extreme wheel compression.

- 1 Detach front wheels. (Refer to section A)
- 2 Use spring clamp 124 589 06 31 00 to clamp and remove front axle springs.

M

Do not use impact screwdriver to clamp front axle springs.

- 3 Unscrew front axle damper strut at upper damper strut mounting (6) whilst steadying the piston rod.
- 4 Lower control arm and damper strut (support control arm).
- 5 Install spring travel limiting washer (5) on piston rod (1) over stop buffer (4).
- 6 Assemble damper strut and front axle spring in reverse sequence.

Note

Use new self-locking nuts (9) and washer (8) on the upper damper strut mounting. (Tightening torque 60 Nm).

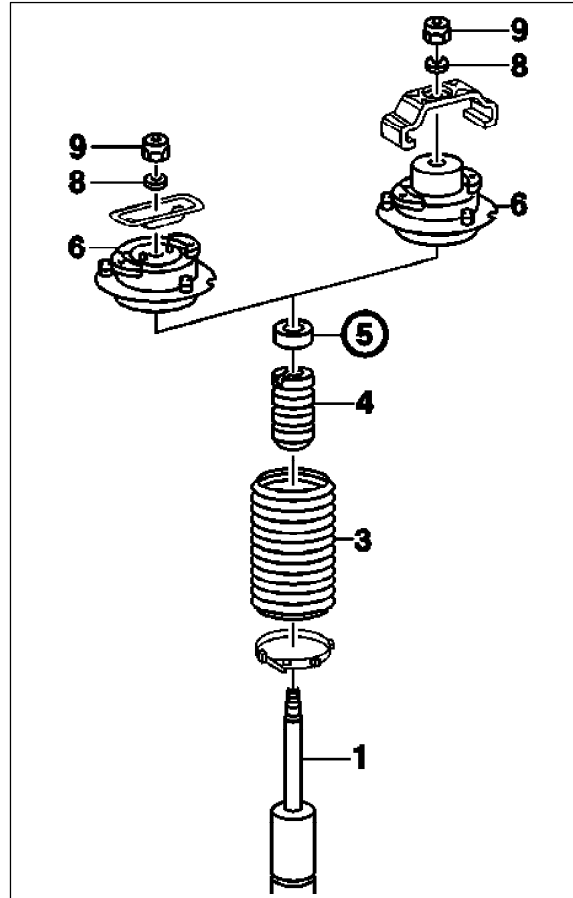

P32-5255-17

C. Modifications to the body

1 Adjusting the front fender

- 1.1 Detach protective side molding on the front fender from the fixing elements, pull to the rear and remove.

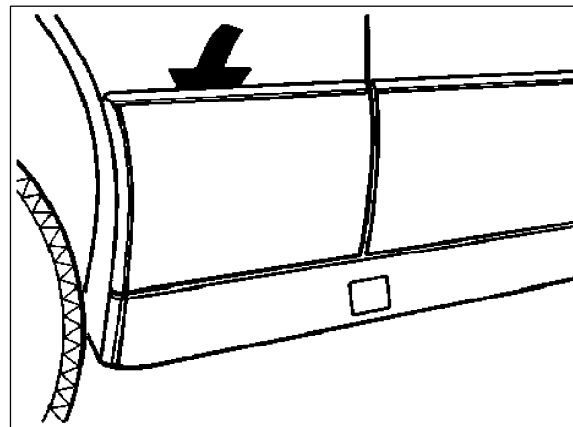

P88-5073-13

1.2 Unscrew bolts (A and B) on fender.

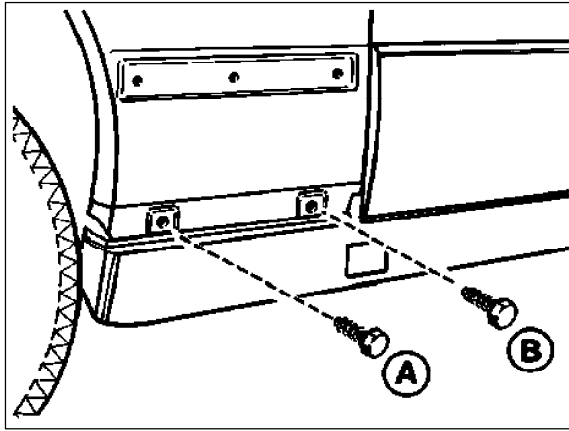

P88-5072-13

1.3 Slacken bolt (A) on side of bumper.

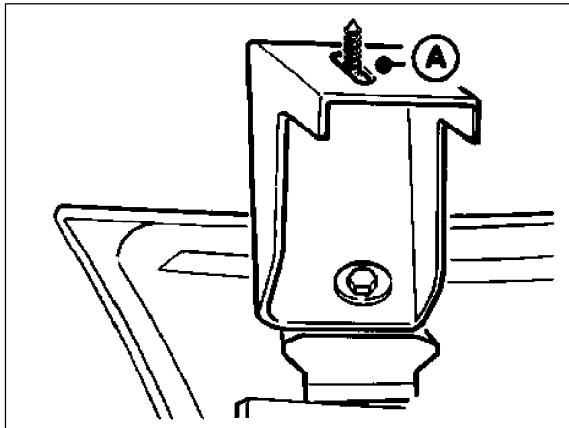

P88-5071-13

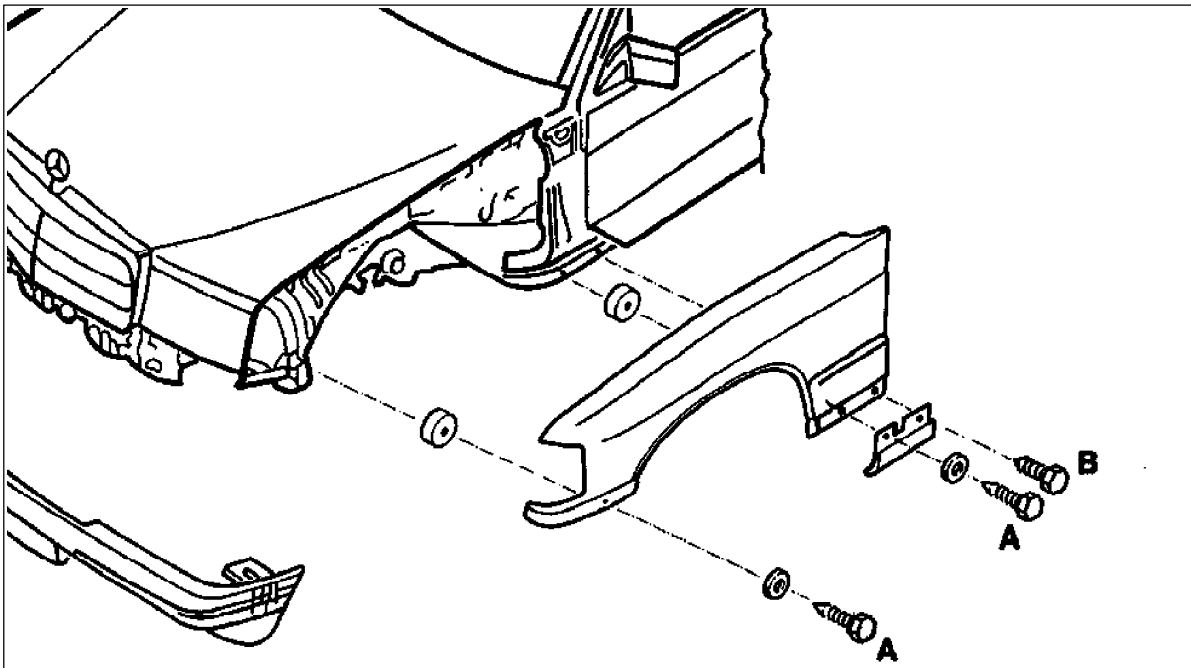

P88-5069-55B

1.4 Press the side part of the bumper downwards and unscrew the bolts for fastening the fender (A and B). Clamp a spacer between fender and body on the left and the right. The bore holes must align to permit troublefree fastening.

1.5 Place one spacer on the left and right between the fender and body in the side area of the bumper.

1.6 Tighten all bolts slightly in accordance with layout. Tighten bolts after a visual inspection.

2 Reworking the body at the front fenders.

The following vehicles are involved:

Model	up to vehicle ident. end no.
124	B 065820
	A 065820
	F 122351

2.1 Crimping over front fender edge:
When converting to wider wheels and tires the inside edges of the front fender must be crimped over 60° over the complete wheel cutout.

2.2 If excessive PVC underbody protection has been applied, grind off excess before crimping over the fender edge.

2.3 Using a hot air gun, carefully heat up outer edges of fender to a maximum of 70°-80°C.

Note

Do not overheat paint whilst applying heat (max. 80°C).

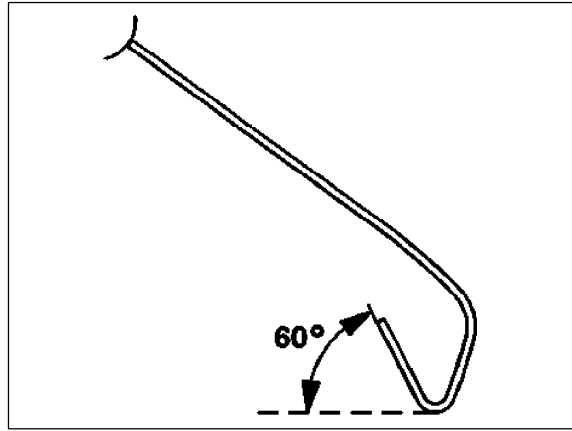

P88-5358-13

2.4 In the marked area (B), the fender edge is crimped over to the inside of the fender in several stages. A plastic hammer must be used to avoid damaging the paint.

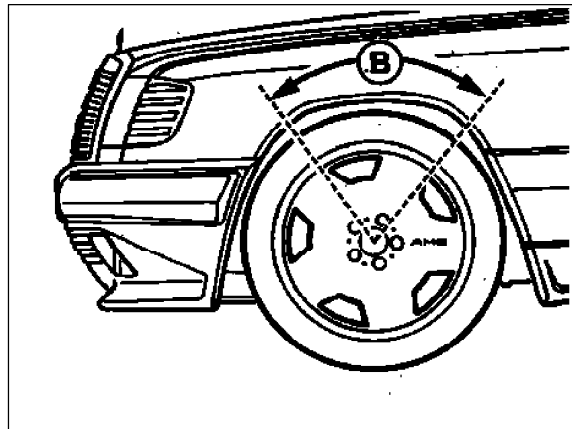

P88-5058-13

M

In order to ensure that the wheel is covered adequately, in certain countries rubber lips have to be attached to the wheelhouses. Any enquiries concerning the individual country-specific regulations should be referred to the national licensing center.

Assembly

1 Attach rubber lip to the wheelhouse.

1.1 The area where the rubber lip is attached must be free from grease (silicone remover).

1.2 The rubber lip and adhesive surface must be at room temperature.

1.3 Align and press on rubber lip.

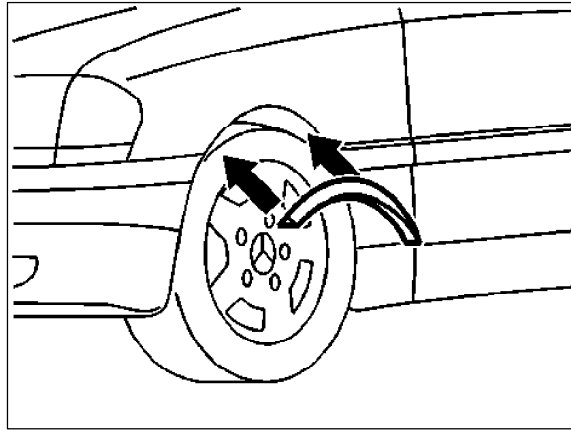

P40-5512-13

D. Fitting the special wheels

1 Screw in centering bolt (tool kit) in upper tapped hole of the wheel hub.

2 Put on AMG light alloy wheel and press on to wheel hub.

3 Screw in wheel bolts and tighten firmly. The wheel bolts must be dry and free from grease. Ensure that the wheel is not incorrectly tensioned through tightening the wheel bolts on one side. (Tighten wheel bolts diagonally in several stages).

M

Only M12×1.5 spherical collar bolts with a shank length of L = 40 mm supplied with the rims are to be used for fastening the wheel.

4 Unscrew centering bolt and replace with a wheel bolt.

5 Lower vehicle.

6 Evenly tighten wheel bolts diagonally to a tightening torque of 110 Nm.

M

AMG light alloy wheel bolts must be retightened after 100-500 km. (Tightening torque 110 Nm).

E. Tire inflation pressure/tire makes/using snow chains

1 The **tire inflation pressure** is to be adjusted in accordance with the tire pressure plate in the fuel filler flap.

2 Recommended **tire makes** can be obtained from the current Service Information "Summer tires in conjunction with AMG special equipment and AMG light alloy wheels from the accessory range".

3 Fitting **snow chains** in conjunction with the AMG wheel/tire combination is not permitted.

F. Technical details

Manufacturer:	AMG/AAG
Model:	H WA124 401 03 02
Wheel size:	7 1/2 J×17 H 2
Offset:	42 mm
Hole circle:	d=112 mm, 5-hole
Permitted wheel load:	615 kg at r _{dyn} =311 mm
Centering:	Central centering d=66.5 H8
Type:	Two-piece light alloy wheels with a pressed rim and a forged wheel spider. Wheel spider: flange-mounted from outside
Marking:	AMG  H WA124 401 03 02 7 1/2 J×17 H 2 ET 42 Date of manufacture AAG JWL symbol
Valve:	Rubber valves in accordance with DIN 7780
Attachment:	Only with M12×1.5×40 mm spherical collar bolts supplied by the wheel manufacturer.
Balancing weights:	Only adhesive weights as used in MB production are permitted.

G. Information for ordering replacement parts

Replacement parts

Designation	Part no.
7 1/2 J×17 H 2 ET 42 light alloy disk wheel with fastening material and wheel cover	B6 602 00 86
Wheel cover	A201 400 04 25
Spherical collar bolt M12×1.5 mm	A124 400 04 70
Rubber valves	A000 400 02 13
Fender widening kit	H WA124 880 0197
Spring travel limiter kit	H WA124 323 0144
Wheel cover kit	B6 602 0091

Note

A set of wheel locking bolts (part no.:
B6 6 40 8103) can be supplied upon request.