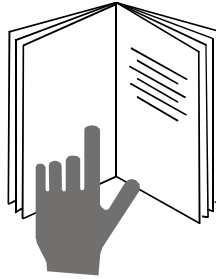

ATTENTION!**READ AND UNDERSTAND
THIS DOCUMENT FIRST**

This introductory information is designed to accompany Klann automotive tool products distributed in the United States of America.

Each tool will have an illustrated description of its physical arrangement and design features.

Each Klann product will also be supplied with illustrated procedures covering its care and use. These procedures are for general guidance only, and are not specific to any particular vehicle unless noted to that effect. Specific procedures will of course vary according to make and model of vehicle. For your own safety, and that of others, please pay strict attention to the safety instructions issued by individual vehicle manufacturers.

In accordance with its policy of constant product improvement, Klann reserve the right to modify tool design and/or specification without notice. Accordingly, customers must satisfy themselves that the product is suitable for the purpose for which they intend to use it.

While every reasonable precaution has been taken to ensure that all information accompanying products is accurate, the authors, illustrators, Klann Tools, nor companies/organizations supplying this information, can hold themselves responsible for any consequences of incorrect information, or error, that may inadvertently occur during its preparation.

Statutory Obligations

Customers are reminded that they must observe all Federal and State laws or regulations governing their ownership, use and storage of Klann products, and that Klann does not warrant that its products comply with all laws or regulations which may affect such products in every jurisdiction. Customers should check which laws or regulations affect them, and comply with those laws or regulations accordingly.

It is the responsibility of the tool owner to ensure that users are aware and have read all safety and operating instructions if the tool is hired or lent.

Liability Clause

The information contained within, nor the tool, or tools, to which such information is applicable, is not intended for use by amateur, DIY, or unqualified mechanics, unless they are adequately supervised by mechanics qualified in the type of work for which the tool was designed.

All Health and Safety laws and regulations should be observed, and safety apparel worn, as appropriate.

Klann accept no liability for damage or injury resulting from errors made by any individual as a result of using the information or procedures provided herein, nor from incorrect use or application of any Klann tool.

SAFETY NOTICE
WHEN WORKING WITH COIL SPRINGS
THE FIRST RULE IS ALWAYS SAFETY FIRST -
THE SAFETY OF YOU, YOUR COLLEAGUES AND YOUR CUSTOMERS!

The KL-0025-1 telescopic coil spring compressor has been designed with a load capacity of up to six (6) times the regular rated load. Damage to the tool may occur only if excessive force is used, or the tool is not operated or maintained as instructed.

Here are some important DOs and DON'Ts

DON'T

- 1 Use the tool for any purpose other than removal/installation of vehicle suspension coil springs.
- 2 Never apply pressure to compress a spring if the pressure plates are not set properly, with the safety lips on the plates fully engaged, around the coils of the spring (Fig.1).
- 3 Never continue to compress any spring after the coils have made contact with each other or end of travel is reached (Fig.2).
- 4 Never use the tool if it is visibly worn, distorted, or damaged.
- 5 Never use a hammer to pound on any part of the tool assembly.
- 6 Never use power tools to operate the KL-0025-1.
- 7 Never use solvents or pressure washer to clean the KL-0025-1, wipe clean only.

DOs

- 1 ALWAYS KEEP THE TOOL CLEAN AND MAINTAIN IT TO THE MANUFACTURER'S INSTRUCTIONS.
A. WIPE CLEAN AFTER EACH JOB.
B. KEEP WELL LUBRICATED WITH MOLYKOTE GN.
- 2 ALWAYS REPLACE ANY DAMAGED PART BEFORE FURTHER USE.
- 3 ALWAYS USE THE CORRECT SIZE SOCKET OR WRENCH ON THE TOOL DRIVE NUT.
4. ALWAYS WEAR SAFETY GLASSES WHEN WORKING WITH THE TOOL (Fig.3).
- 5 ALWAYS READ AND UNDERSTAND (COMPLETELY) THE INSTRUCTIONS FOR OPERATION AND MAINTENANCE OF THE TOOL BEFORE ATTEMPTING TO USE IT.
- 6 USE ONLY KLANN ORIGINAL SPARE PARTS.

Fig 1

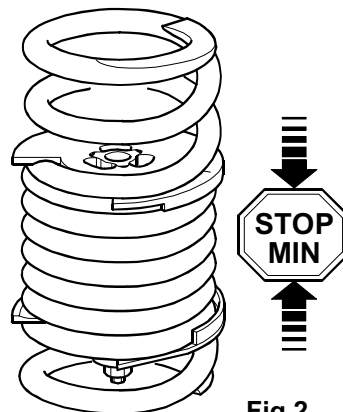
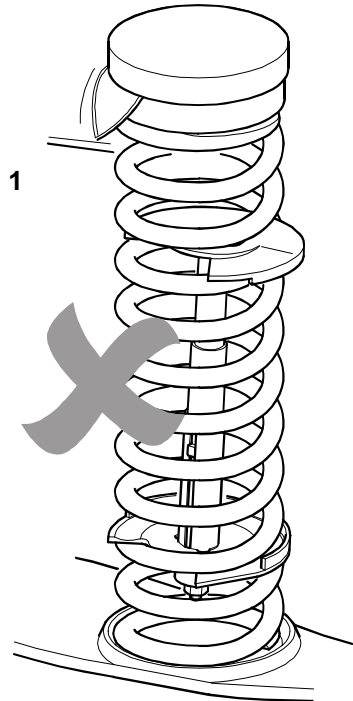
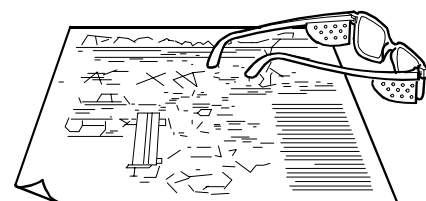
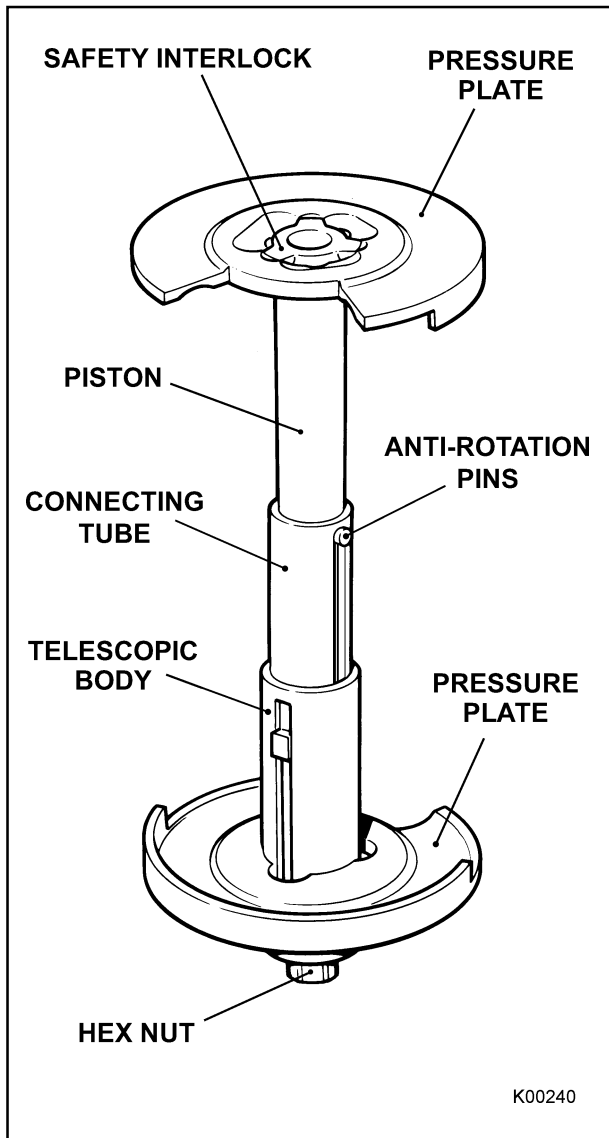

Fig 2

Fig 3





SPECIAL FEATURES

- 1 **Machined Steel Cylinder:** High tensile strength.
- 2 **Drop Forged Pressure Plates:** Very strong.
- 3 **Case Hardened:** Very durable.
- 4 **Axial Bearing:** Absorbs load and reduces effort.
- 5 **Pitched Pressure Plates:** Ensures maximum contact with spring coils.
- 6 **Hardened Spindle:** Ductile for long life and very strong.
- 7 **Dual Hex. Drive:** Secondary drive in the event of shear pin failure.
- 8 **Automatic Idle:** Prevents damage to tool body
- 9 **Safety Lock:** Prevents tool body slipping
- 10 **Patented Interlock:** Prevents rotation of the tool and pressure plates.
- 11 **Wide Range of Pressure Plates:** Wide application.

PATENTED 'INTERNAL' SPRING COMPRESSOR FOR CONTROL ARM SPRINGS

DESCRIPTION

The KL-0025-1 is a telescopic, cylinder type spring compressor system. It is designed for quick and easy removal and installation of coil springs in wishbone and multi-link, independent suspensions, usually without the need to dismantle the axle (there may be exceptions).

The compressor consists of a solid steel, telescopic body with an internal drive spindle driven by a hex. nut on which hand tools may be used.

The drive spindle is located in an axial bearing at its drive end. This bearing absorbs tension and friction forces, reducing the required operational effort.

At the other end of the drive spindle is a three-point safety interlock which engages in the pressure plate selected to suit the spring to be removed/installed.

The complete assembly is case hardened to increase tensile strength and give better sliding wear.

A range of machined, drop-forged pressure plates is available to cover a wide range of coil spring diameters.

Each pressure plate has a safety lip to eliminate slip, and is designed to fit the pitch of the spring to ensure maximum surface contact between the pressure plate and the spring coils. This eliminates the risk of coil spring bending during compression.

Pressure plates are supplied in pairs, with the lower plate differing from the top plate.

The lower plate has a machined, central hole through which the body of the tool is inserted. The lower plate will then engage with a profile on the lower end of the tool.

The top plate has a safety interlock which engages with the three-point interlock on the drive spindle.

The KL-0025-1 has a dual drive system, the outer drive nut incorporates a shear pin to protect the tool from damage due to overtightening or coil bound springs. In the event of the shear pin failing a smaller drive nut is available to manually release the tool from the spring.

The KL-0025-1 will automatically idle when the spring is fully relaxed, so the tool cannot be damaged

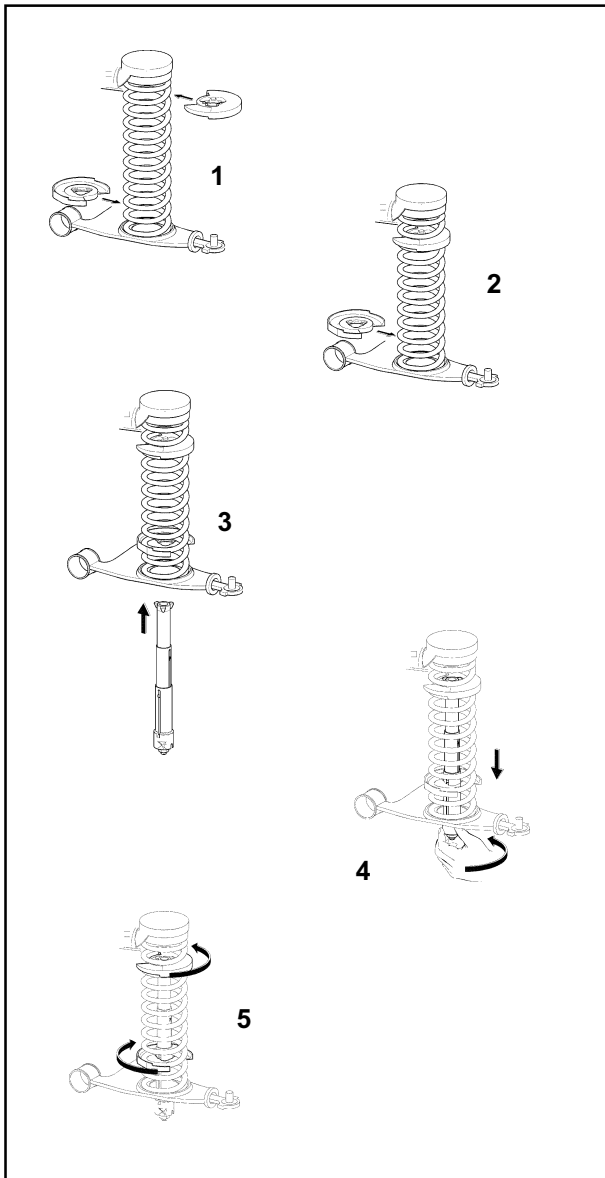

WARNING

The KL-0025 is to be used only by personnel trained in strut work.

DO NOT USE THE KL-0025 on coil springs which have a spring pressure over 26,000N (2600kg).

STOP compressing the spring before it becomes coil bound or end of travel is reached.

When the spring is released ensure that jaws do not contact the spring pan on the strut.

Don't extend the KL-0025-1 fully when fitting to spring coils as the spring will be partially compressed on the vehicle. The KL-0025-1 has a maximum distance of 317mm which may be exceeded when the spring is relaxed off the vehicle.

PROCEDURE

This procedure is to be carried out only by personnel trained in the use of spring compressors.

Inspect the tool for any signs of damage. Do not use a damaged tool.

Select the correct sized pressure plates for the spring to be compressed.

Ensure that spring coils fit behind the safety lips of both pressure plates, with a minimum of 240° of contact between the coils and the jaws.

Finally, once the spring has been relaxed again (i.e. removed, or reset on the vehicle) remove the tool immediately to prevent damage to the pressure plates, or the tool itself.

Removing the spring from the vehicle

Jack up the vehicle using a suitable lifting device.

If the spring to be removed contains a shock absorber, remove the shock absorber in accordance with the vehicle manufacturer's procedure.

Select the correct pair of pressure plates for the spring to be compressed.

Locate the top pressure plate in the top half of the spring, ensuring that it engages correctly with the spring coil (fig 1).

Locate the lower pressure plate in the lower half of the spring, ensuring that it engages correctly with the spring coil (fig 2).

Hand operate the spring compressor to extend it to a length slightly greater than the distance between the pressure plates on the spring.

Insert the spring compressor up through the access hole in the suspension arm, then through the lower pressure plate and into the top plate (fig 3)

(If the access hole is in the upper suspension arm, follow the same procedure with the pressure plate positions reversed).

Once through the top pressure plate, twist the spring compressor through 60° to engage the three-point interlock on the top pressure plate, so that the tool then hangs from the top pressure plate (fig 4).

Rotate both pressure plates by hand in opposite directions, towards either end of the spring, until the pressure plates are fully engaged with the spring compressor (fig 5).

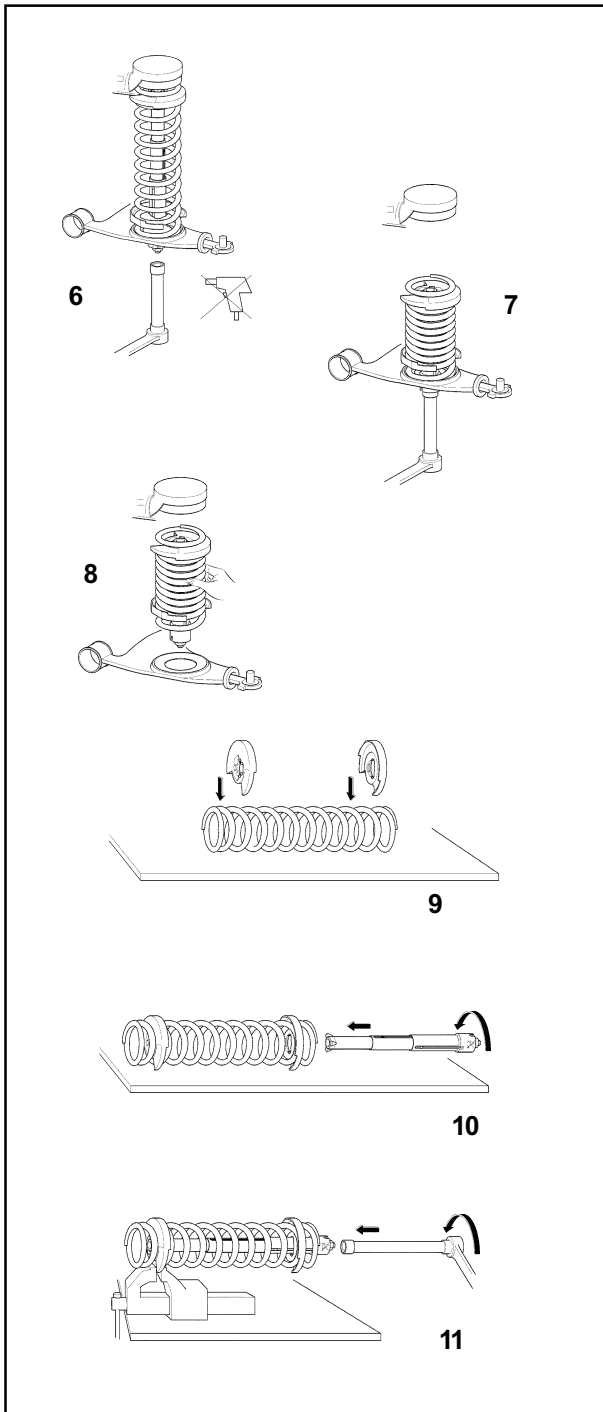

PROCEDURE - Continued

NOTE: If compressing a spring which is normally curved when located on the vehicle, ensure that the pressure plates are 180° opposite each other so that the spring is compressed straight.

Using a hand tool on the drive nut, compress the spring until it is just coil bound. Do not compress beyond this point (figs 6 & 7).

If the drive spindle is overloaded, the safety pin in the main drive will break to prevent overload accidents. However, the drive mechanism remains active through the secondary drive nut, so a compressed spring can still be released.

Withdraw the compressor and compressed spring together (fig 8).

Decompress the spring by carefully turning the drive nut in the opposite direction.

Refitting the spring to the vehicle

Refitting the spring is a reversal of the procedure for its removal.

Remember though to arrange the pressure plates at 180° to each other on springs that are curved when installed on the vehicle.

Compressing the spring is easier if one of the pressure plates is mounted in a vise (figs 9, 10 & 11).

When decompressing the spring onto the vehicle, ensure that the spring seats correctly at both ends.

TIME SAVING

The KL-0025-1 limits the necessity for suspension dismantling to removal of a shock absorber in some cases, thus reducing job time by up to 2 hours.

TOOLS REQUIRED

Primary drive	19mm Wrench/socket
Secondary drive	10mm Wrench/socket

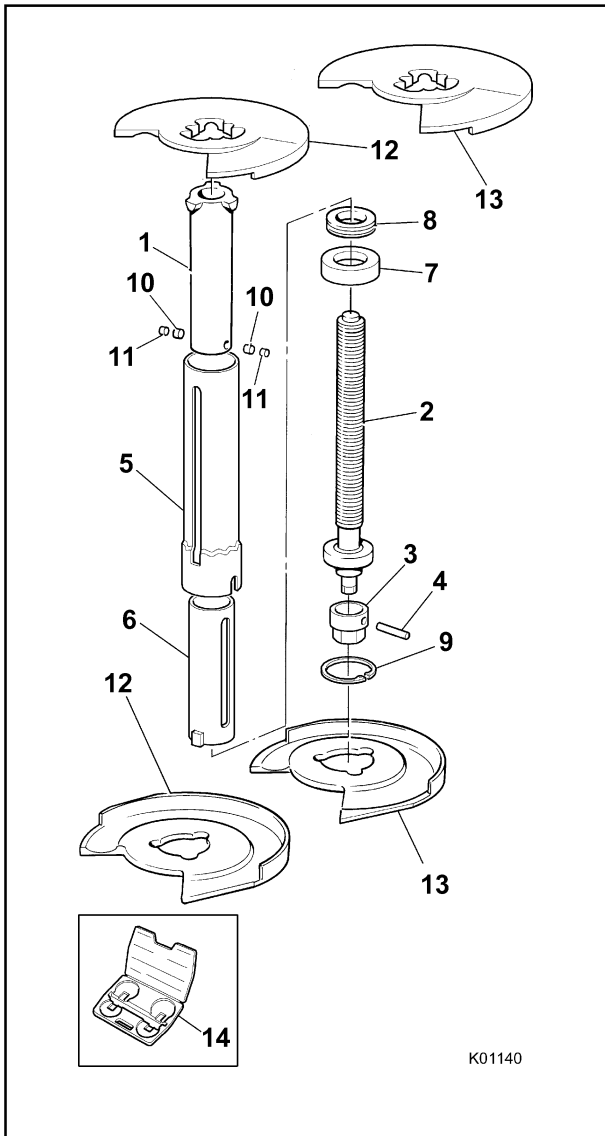

MAINTENANCE

Use only *Molykote GN* lubricant on the compressor spindle (KL-0014-0030).

KL-0025-1 is manufactured from the finest materials to give a long and efficient life, and can be fully serviced. Service kits, rebuild service and spares are all available through your KLANN dealer.

Use only KLANN original parts.

SPARES

1 PISTON	KL-0021-0001
2 SPINDLE	KL-0025-1008
3 DRIVE NUT	KL-0025-1009
4 CYLINDRIC PIN 4 x 26	KL-0025-1010
5 CASING	KL-0025-1011
6 CONNECTING TUBE	KL-0021-0004
7 INSERT	KL-0021-0005
8 BEARING	KL-0021-0006
9 CIRCLIP B38	KL-0021-0020
10 ROLL PIN 6x 6	KL-0021-0021
11 ROLL PIN 6x 4	KL-0021-0022
12 PRESSURE PLATES SIZE 1 (95 - 120mm)	KL-0025-11
13 PRESSURE PLATES SIZE 2 (120 - 140mm)	KL-0025-12
15 PLASTIC CASE	KL-0025-1090

TECHNICAL SPECIFICATION/DIMENSIONS

Maximum Jaw Opening	317mm
Minimum Jaw Opening	110mm
Working Travel	207mm
Overall Length	263mm
Maximum Spring Load	26,000N
Ultimate Stress Limit	120,000N
Minimum Spring Capacity	110mm OD
Maximum Spring Capacity	190mm OD
Safety Factor	4 - 20
Case Hardened Cylinder	
Drop Forged Jaw/ Interlock	
Can be used on or off the vehicle	
Can be fully serviced	
No spring load taken through Spindle	
Spring load taken through body	
240° Spring contact surface	
Self-locking Carriers	
Suitable for long springs	
Complete range of plate sizes for all springs	
Approved by Underwriter	
BGS Approved	

KL-0025 - FULLY SERVICEABLE = LONG LIFE

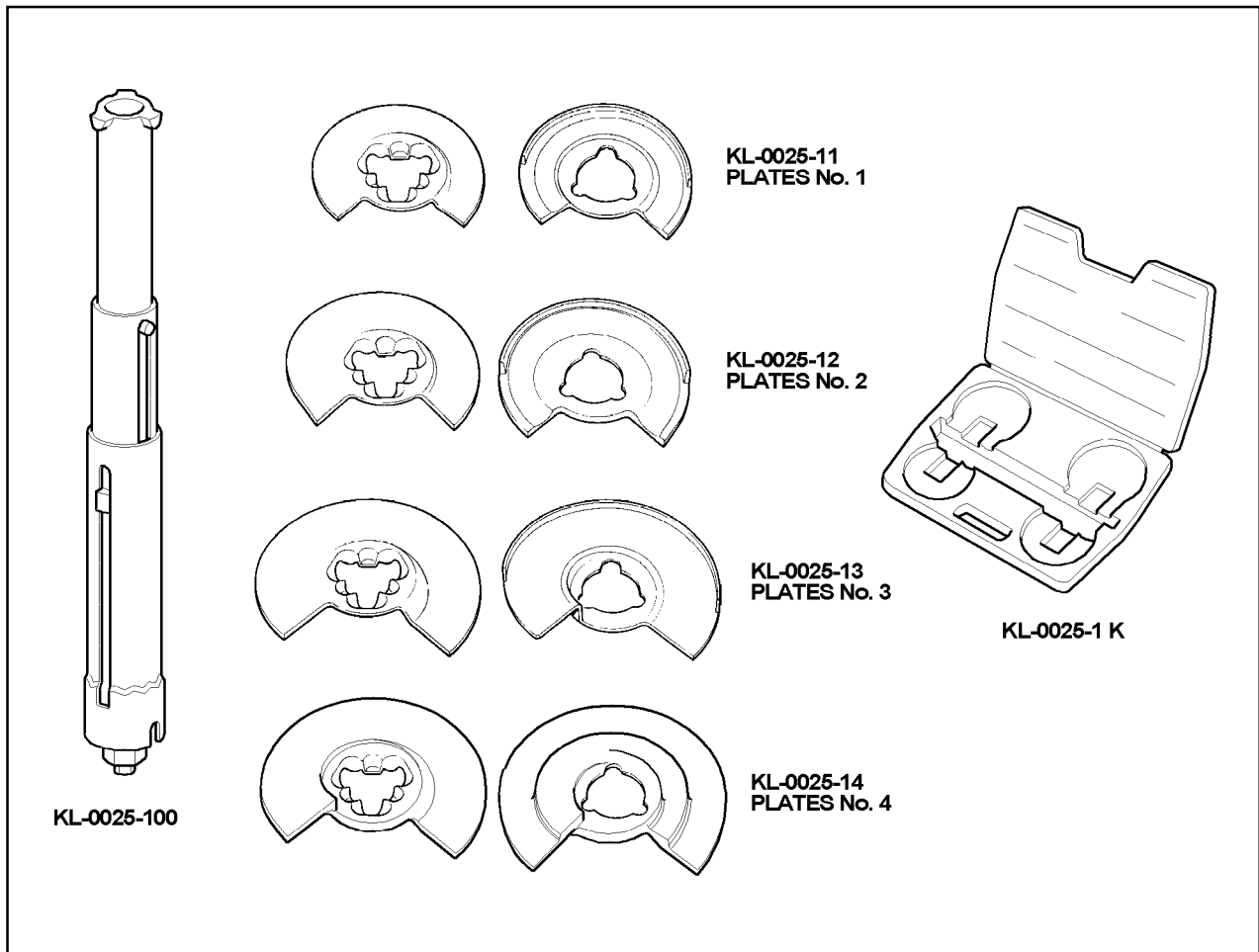

DESCRIPTION

The plates for KL-0025-1 are dropped forged for maximum strength and safety.

They are machined to ensure accurate engagement with the compressor interlocks.

A safety lip prevents the jaws slipping and the pitch ensures maximum contact with the spring.

The range of plates provides coverage for all popular spring sizes.

ACCESSORIES

KL-0025-100 CYLINDER
KL-0025-11 PAIR OF PRESSURE PLATES No.1
KL-0025-12 PAIR OF PRESSURE PLATES No.2
KL-0025-13 PAIR OF PRESSURE PLATES No.3
KL-0025-14 PAIR OF PRESSURE PLATES No.4

KL-0025-1 K PLASTIC CASE