

Operation no. of operation texts and work units or standard texts
and flat rates:
30-4105

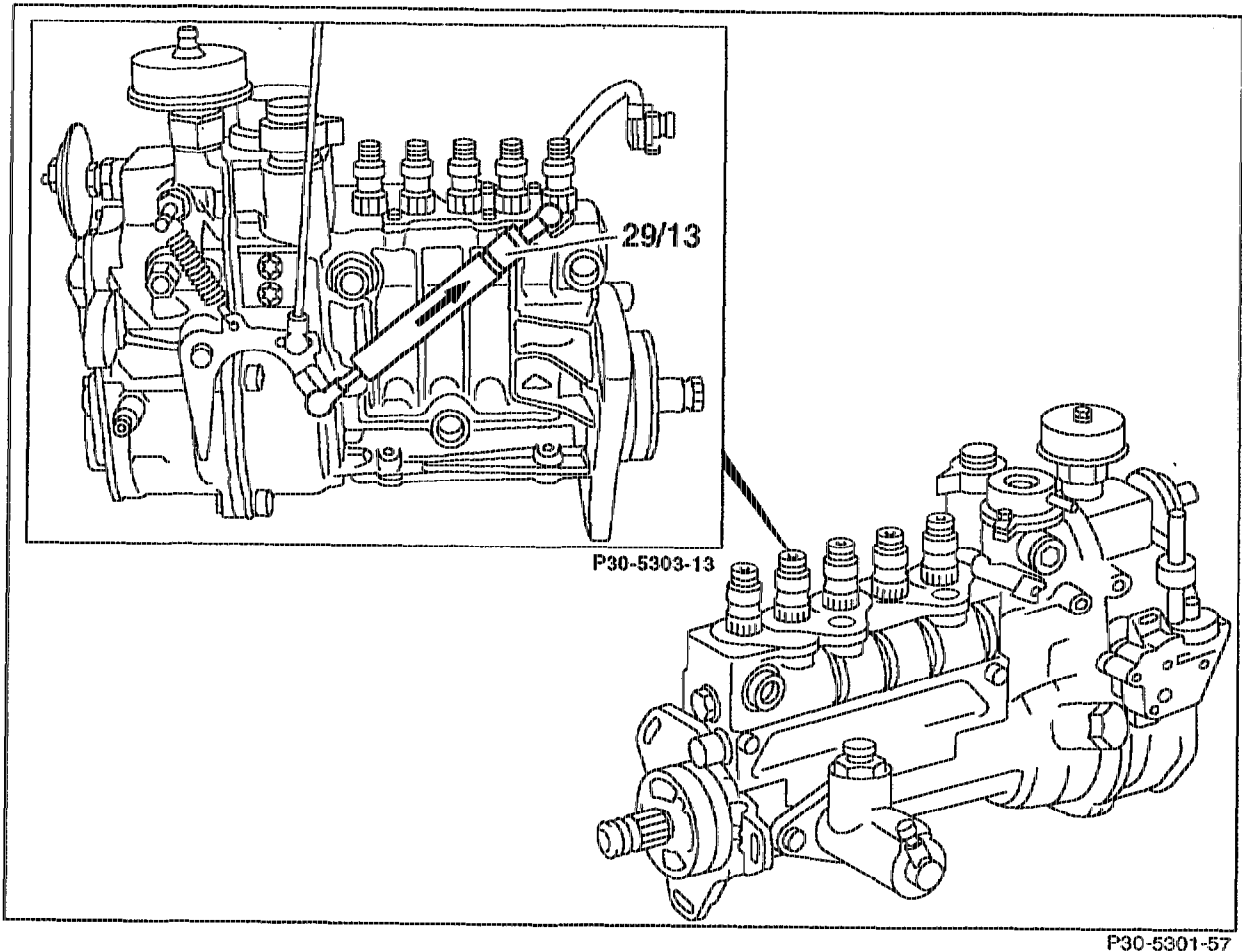

Engine 605.911

Intake manifold remove, install, replace gasket (14-1310).

Engine 606.910

Variable resonance intake manifold remove, install, replace gasket (14-1961).

All models

Ball sockets of accelerator control
damper (29/13) at injection pump press off, press on.

Note

Pay attention to installation position (see arrow
on accelerator control damper).

Notes

Restoring spring modified. Strengthened restoring spring to ensure accelerator control damper moves back when engine idling.

Production breakpoint: as of June 1993

Model	Engine	Engine end no. automatic transmission
124.104/107/126/129/ 186	605.911	000451
124.131/191	606.910	000179

Restoring spring at injection pump with increased spring force.

Production breakpoint: as of September 1993

Model	Engine	Engine end no. manual transmission
124.104/107/126/129/ 186	605.911	005093
124.131/191	606.910	001671