

ENGINE 601, 602, 603 (except, 602.982)

Illustration shows oil filter without air-oil cooler connections

- 271 Nut M 8
- 272 Stud bolt M 8
- 273 Cover
- 274 O-ring
- 275 Oil filter housing
- 276 Return flow pipe
- 277 Check valve
- 278 O-ring
- 279 O-ring
- 280 Oil filter element
- 280a Full-flow filter
- 281 Stand pipe
- 282 Circlip
- 283 Dished washer
- 284 Spring
- 285 Valve cone bypass valve
- 286 Valve seat return flow check valve
- 287 Valve cone return flow check valve
- 288 Compression spring
- 289 Dished washer

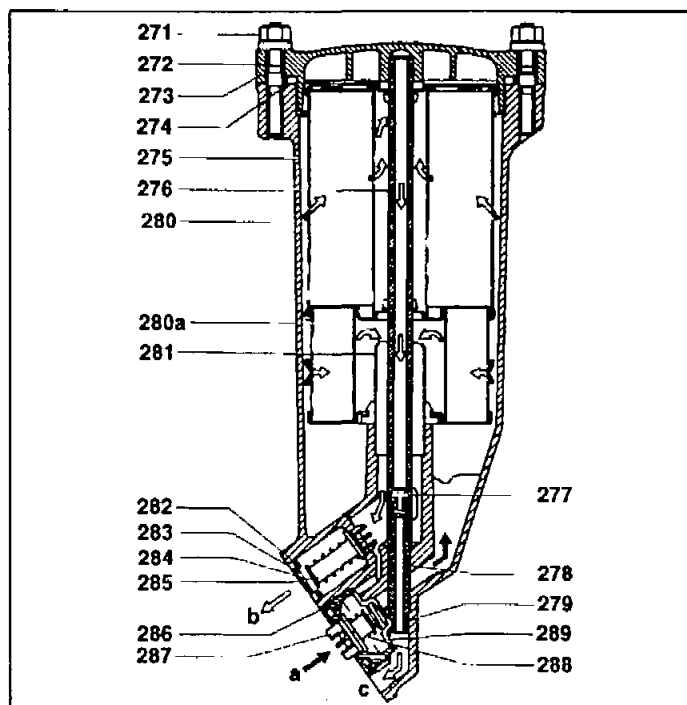

P18.00-0403-12

GF	Position		GF18.20-P-1101-01A GF18.20-P-1101A/2
	Task	Filtering out dirt particles (soot, abrasion) from engine oil.	
GF	Design		GF18.20-P-1101-03A GF18.20-P-1101A/2
GF	Function		GF18.20-P-1101-04A GF18.20-P-1101A/3



The oil filter housing (11) is located at the rear left of the engine.

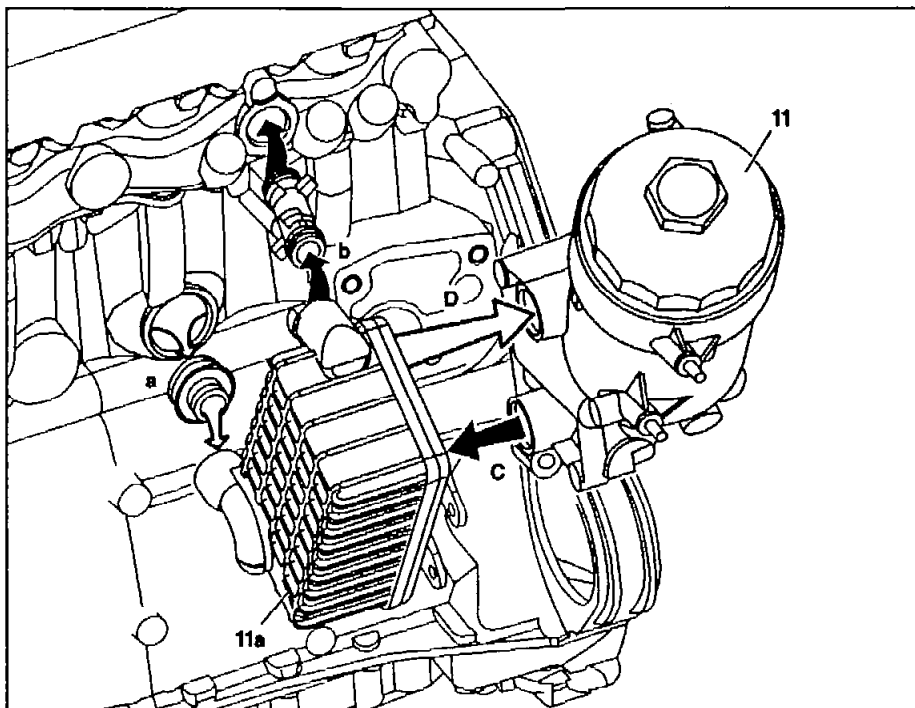

P18.00-0215-06

Oil filter without air-oil cooler connections

- 271 Nut M 8
- 272 Stud bolt M 8
- 273 Cover
- 274 O-ring
- 275 Oil filter housing
- 276 Return flow pipe
- 277 Check valve
- 278 O-ring
- 279 O-ring
- 280 Oil filter element
- 280a Full-flow filter
- 281 Stand pipe
- 282 Circlip
- 283 Spring washer
- 284 Spring
- 285 Valve cone bypass valve
- 286 Valve seat return flow check valve
- 287 Valve cone return flow check valve
- 288 Compression spring
- 289 Dished spring

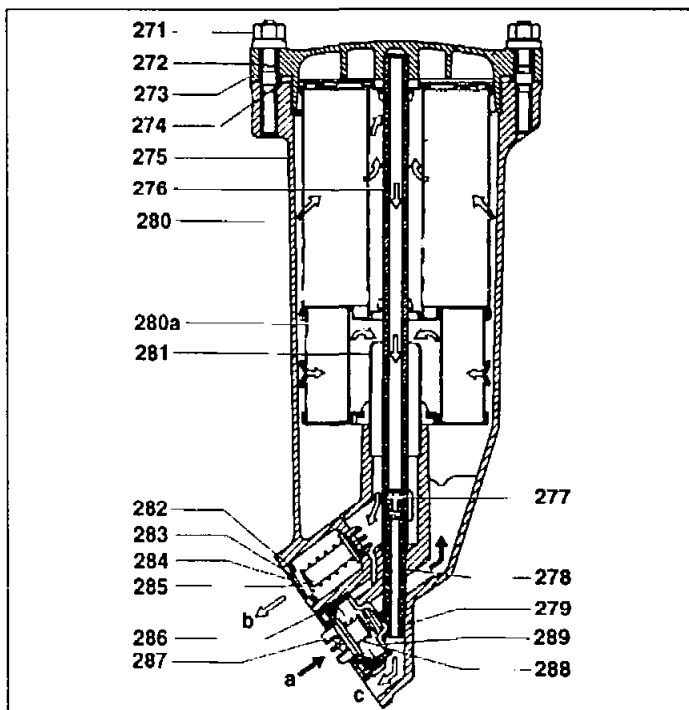

P18.00-0403-12

Oil filter with air-oil cooler connections

- 271 Nut M 8
 - 272 Stud bolt M 8
 - 273 Cover
 - 274 O-ring
 - 275 Oil filter housing
 - 276 Return flow pipe
 - 277 Check valve
 - 278,279 O-ring
 - 280 Oil filter element
 - 280a Full-flow filter
 - 281 Stand pipe
 - 282 Circlip
 - 283 Dished washer
 - 284 Spring
 - 285 Valve cone bypass valve
 - 286 Valve seat return flow check valve
 - 287 Valve cone return flow check valve
 - 288 Compression spring
 - 289 Dished washer
 - 295 Thermostat
 - 296 Spring
- A Unfiltered oil to air-oil cooler
 B Unfiltered oil from air-oil cooler
 a To oil filter
 b To bearing points
 c To oil pan

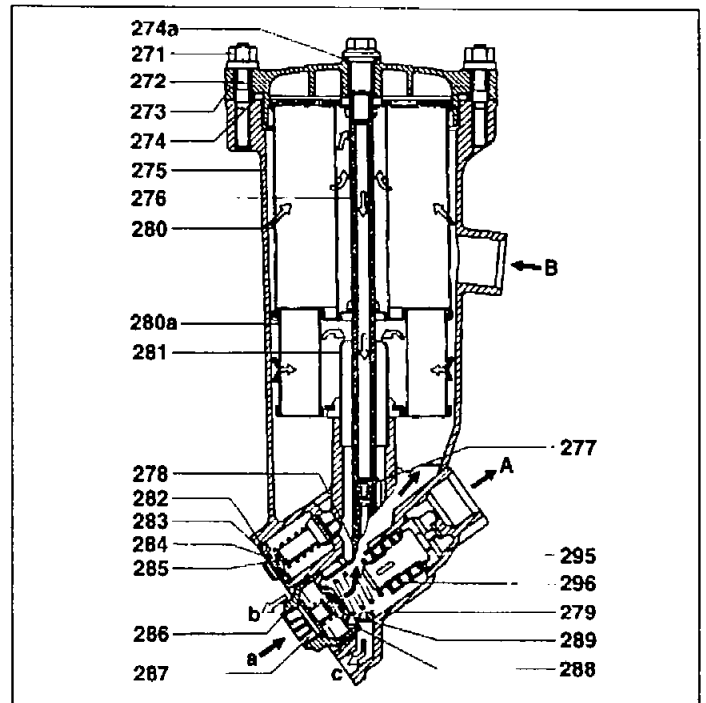

P18.00-0402-12

GF18.20-P-1101-04A	Oil filter function	
--------------------	---------------------	--

The oil flows from the feed gallery (a) through the return flow check valve (286, 287) into the oil filter housing and flows directly into the oil filter element (280). It flows through the oil filter element and along the stand pipe (281) and the gallery (b) to the main oil gallery and onto the bearing points.

The finely filtered oil flows through the return flow pipe (276) and the gallery (c) to the oil pan.

A rubber seal is provided in the oil filter element (280) in order to separate the full-flow and bypass flow.

When changing the oil filter element, unscrew the cap (273) and pull it up slightly.

When this is done, the return flow pipes (276) attached to the cover opens a passage which connects the galleries (b) and (c) to each other. The oil in the oil filter flows back through the gallery (c) into the oil pan.

The return flow pipe is fitted to engines 601, 602 and in engine 603 - 1st version as of 02/92; this return flow pipe can be unscrewed when changing the oil to facilitate removing the oil filter cover.

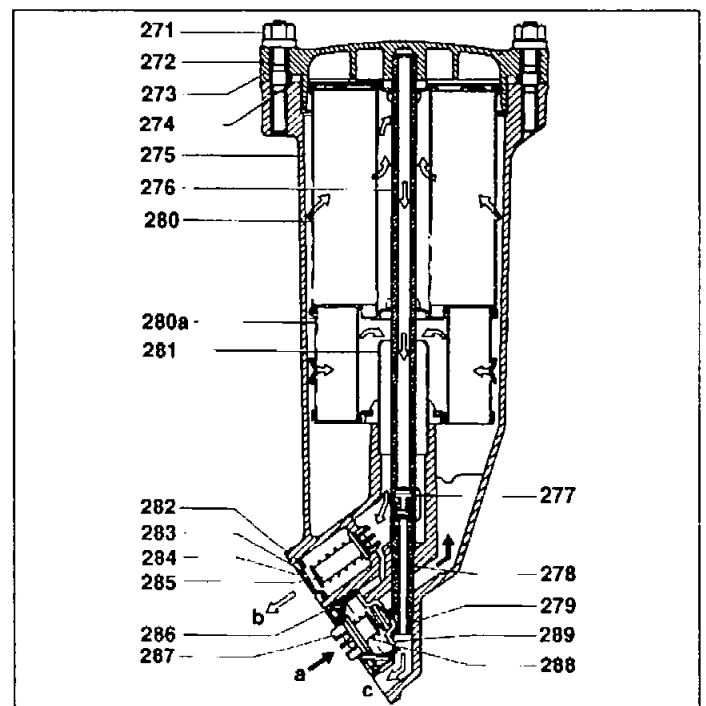

P18.00-0403-12

