

ENGINE 601, 602, 603 (except, 602.982)

- 1 Bucket tappet
- 2 Valve collets
- 3 Valve spring retainer
- 4 Valve spring
- 5 Valve stem seal
- 6 Valve

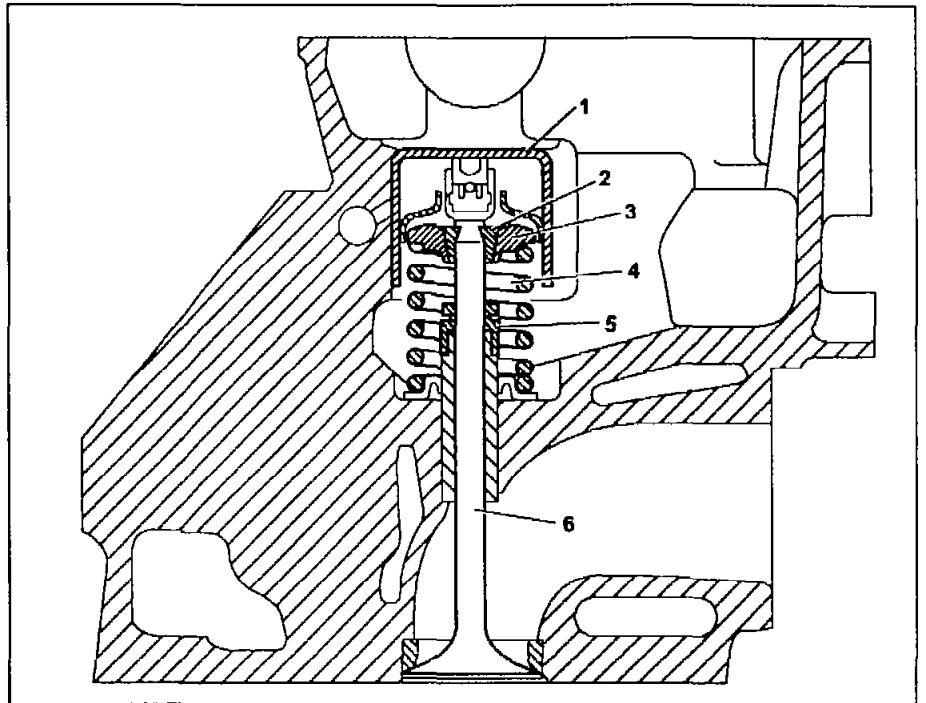

D05.30-0002-06

	Removing, installing		
1	Remove camshaft		05-220
2	Remove injection nozzles	Naturally aspirated engine Turbo engine	07.1-230 07.1-6810
3	Position pistons of the relevant cylinder to TDC	Use TDC detector	
4	Insert retaining lock for crankshaft/starter ring gear		03-500
5	Connect cylinder leak tester	Pressurize compression chamber of the relevant cylinder to about 5 bar. Use connector on engines with oblique injection.	WH58.30-Z-1030-05A 602 589 00 63 00
6	Remove bucket tappet (1)	only at the relevant cylinder	
7	Remove valve springs and valve stem seals	 	AR05.30-D-3510-02A AR05.30-P-3500HX/2 603 589 01 40 00 111 589 25 61 00 601 589 01 59 00 606 589 00 37 00
8	Repeat the procedure for the remaining cylinders from step 4	Remove retaining lock, turn crankshaft on, install.	
9	Install in the reverse order		

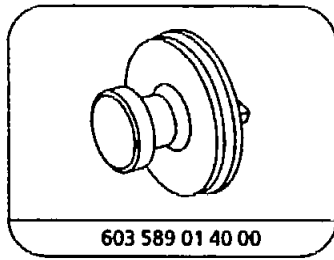

603 589 01 40 00

Retaining lock

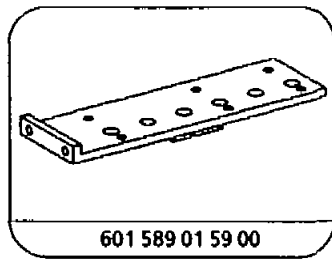

601 589 01 59 00

Assembly board

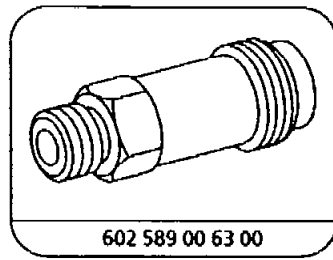

602 589 00 63 00

Connector

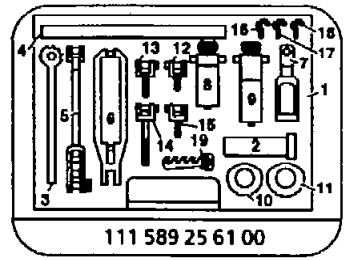

111 589 25 61 00

Valve assembly tools case

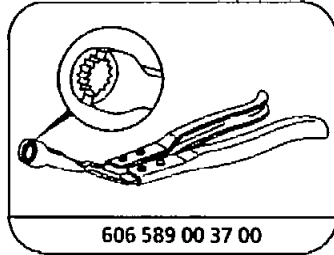

606 589 00 37 00

Pliers

Commercially available tools (see Workshop Equipment Manual)

Number	Designation	Make (e.g.)	Order number
WH58.30-Z-1030-05A	Cylinder leak tester	Bosch	0 681 001 901 EFAW 210 A

AR05.30-D-3510-02A	Removing and installing valve springs and valve stem seals	<input checked="" type="checkbox"/> 601 589 01 59 00 Assembly board <input checked="" type="checkbox"/> 603 589 01 40 00 Holding wheel <input checked="" type="checkbox"/> 606 589 00 37 00 Pliers <input checked="" type="checkbox"/> 111 589 25 61 00 Case for valve installation tools	
--------------------	--	--	--

1.1 If cylinder head removed:
Bolt cylinder head to assembly board 601 589 01 59 00 with four cylinder head bolts (arrows).

i Only if cylinder head removed.

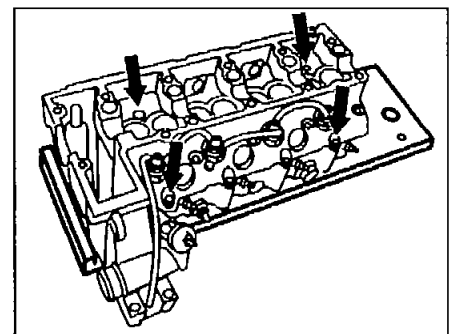

P05.00-0024-01



1.2 If cylinder head installed: insert retaining wheel (01).



P05.20-0342-01

2 Insert matching guide bush (11) into bucket tappet bore, screw detent with pivot bearing with suitable retaining fork (17) into thread of camshaft bearing cap and align.

ⓘ Do not use the threads of the cylinder head cover as the cylinder head cover is attached with self-tapping bolts.

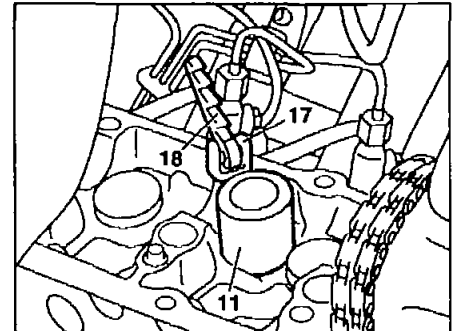

D05.30-0008-01

3 Assemble thrust fork (6) with lever handle (3).

4 Insert assembly cartridge (9) into the guide bush (11). Attach thrust fork (6) to the mating bearing (18) and position at the mounting pins of the assembly cartridge (9).

5 Apply slight pressure to thrust fork (6) and to knurled screw and at the same time slowly rotate the knurled screw of the assembly cartridge (9) (arrow) until the inner locating drift with its tips is felt to engage between the valve collets.

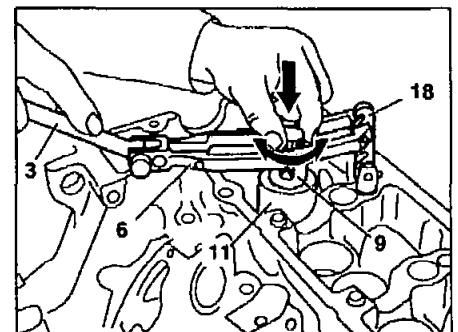

D05.30-0060-01

6 Apply slight pressure with your thumb to the knurled screw of the assembly cartridge (9) and press thrust fork (6) down as far as the stop (use extension if necessary). The valve collets are removed automatically.

7 Slacken thrust fork (6) and take off.

8 Take out assembly cartridge (9) with the removed valve collets.

ⓘ The valve collets can remain in the assembly cartridge until installed but all the valve springs or valves should be removed, e.g. if cylinder head removed it is then possible to take the valve collets out of the assembly cartridge by pulling out the knurled screw.

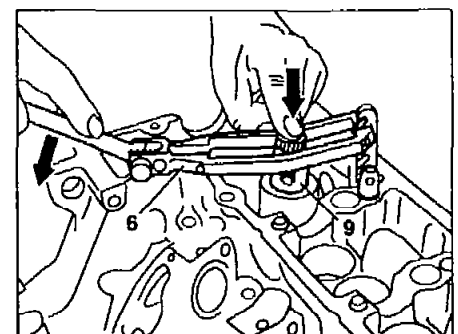

D05.30-0061-01

- 9 Check whether the valve collets are in the assembly cartridge (9) and repeat steps 4 to 7, if necessary.
- 10 Take out guide bush (11).

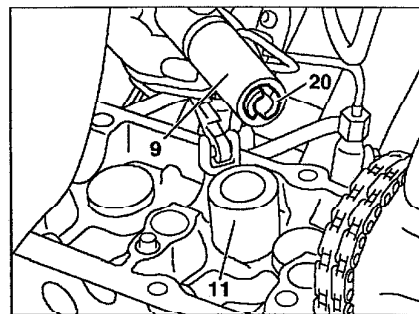

D05.30-0011-01

- 11 Remove top valve spring retainer (3) and valve spring (4).

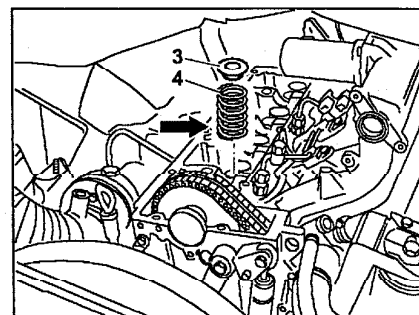

D05.30-0005-01

- 12 Use  pliers to pull valve stem seal (5) off the valve stem.
- 13 Take out bottom valve spring retainer, inspect for pitting, replace if necessary and re-insert. Inspect valve stem for pitting, remove if necessary.

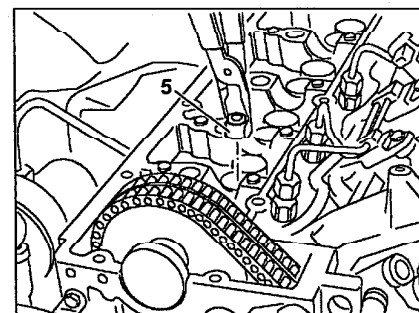

D05.30-0006-01

- 14 Fit protective cap (12) (contained in parts supplied) onto the valve stem (6) and oil well.
- 15 Insert new valve stem seal (5) into assembly drift and press onto valve stem (6) as far as the stop.
- 16 Take off protective cap (12).

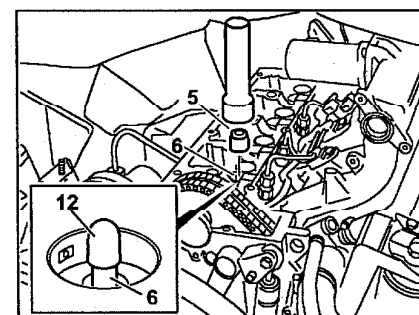

D05.30-0007-01

- 17 Insert valve spring and top valve spring retainer.
- 18 Insert guide bush (11) into the cylinder head.

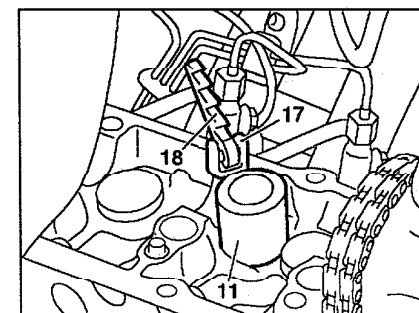

D05.30-0008-01



- 19 Insert assembly cartridge (9) with valve collets inside into the guide bush (11), attach thrust fork (6) to mating bearing (18) and position with slight pressure onto the two mounting bolts of the assembly cartridge (9).
- 20 Press down thrust fork (6) (arrow). Pull the knurled screw of the assembly cartridge (9) up (arrow), this releases the pressure on the thrust fork (the valve collets are thus installed).
- 21 Check whether the valve collets (9) are correctly inserted; repeat steps 2 to 8 and 17 to 19, if necessary.
- 22 Detach all the special tools from the cylinder head.

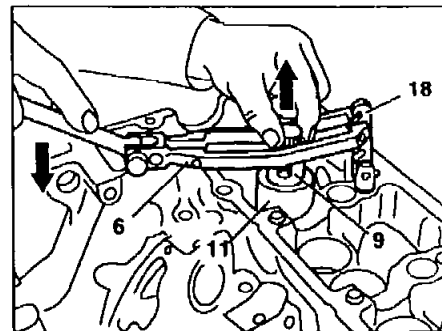

D05.30-0062-01

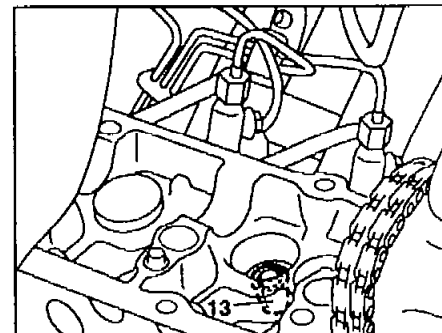

D05.30-0013-01