

05-2220 Replacing end cover in camshafts

Preceding work:
Camshafts removed (05-2200)

Operation no. of operation texts and work units or standard texts
and flat rates:

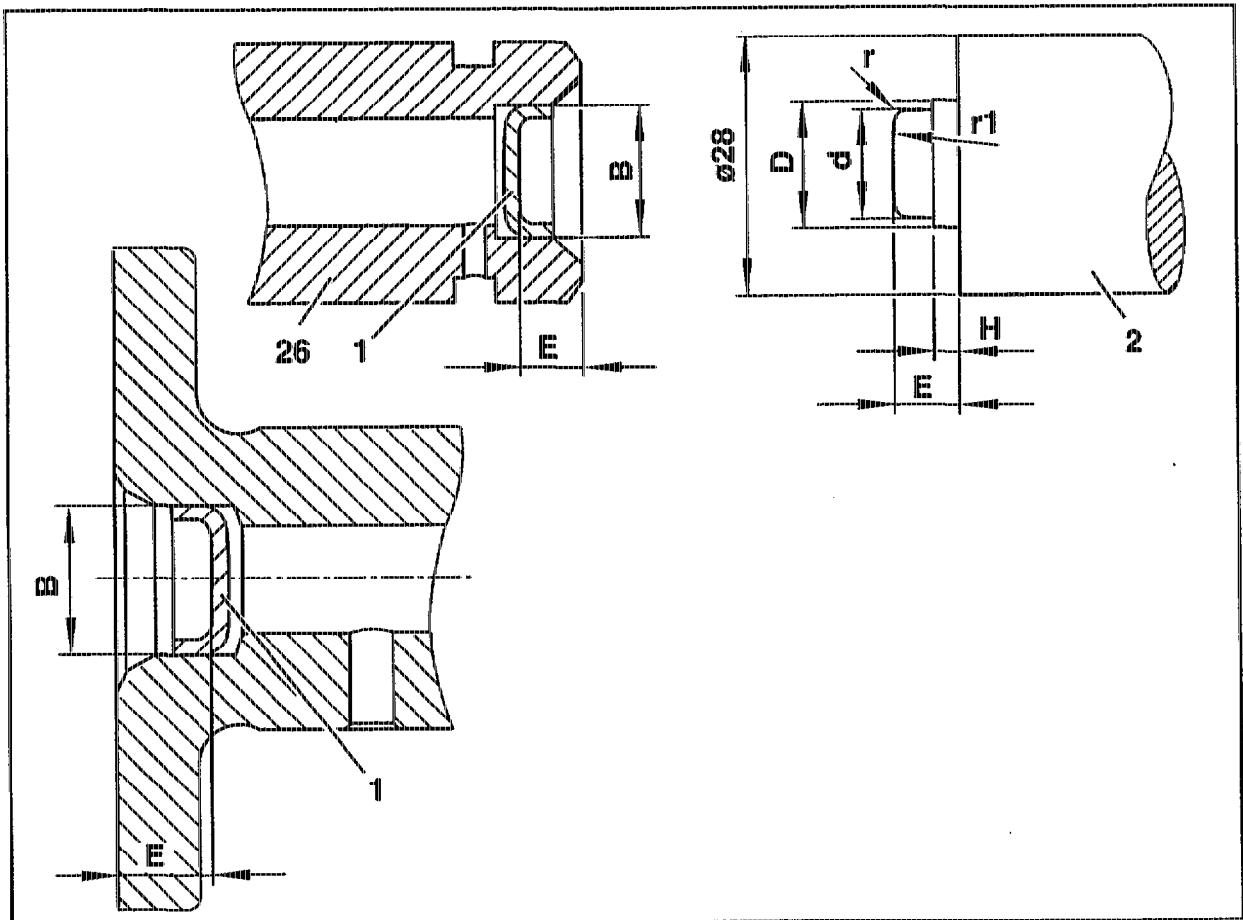

P05.20-0261-57

Cover (1)	prise out with a screwdriver.
Hollow-drilled camshaft (26)	clean.
Bore (B)	inspect (see table for dimensions).
End cover (1)	knock in with drift (2) (shop-made tool).



Use new end cover (1).

The end cover must not be seated on the end of the bore.

It is essential to maintain the insertion depth (size E).



Data in mm

Camshaft (26)		Inlet, exhaust at rear
Bore (B)		14.00 – 14.04
End cover DIN 443 (1)		A14
Insertion depth size (E)		9.3
Insertion drift (2) dimensions (shop-made)	d	11.7
	D	13.7
	H	4,3
	r	1
	r1	35