

05-2220 Replacing end cap in rear of camshaft

Preceding work:
Camshaft removed (05-2200)

Operation no. of operation texts and work units or standard texts
and flat rates

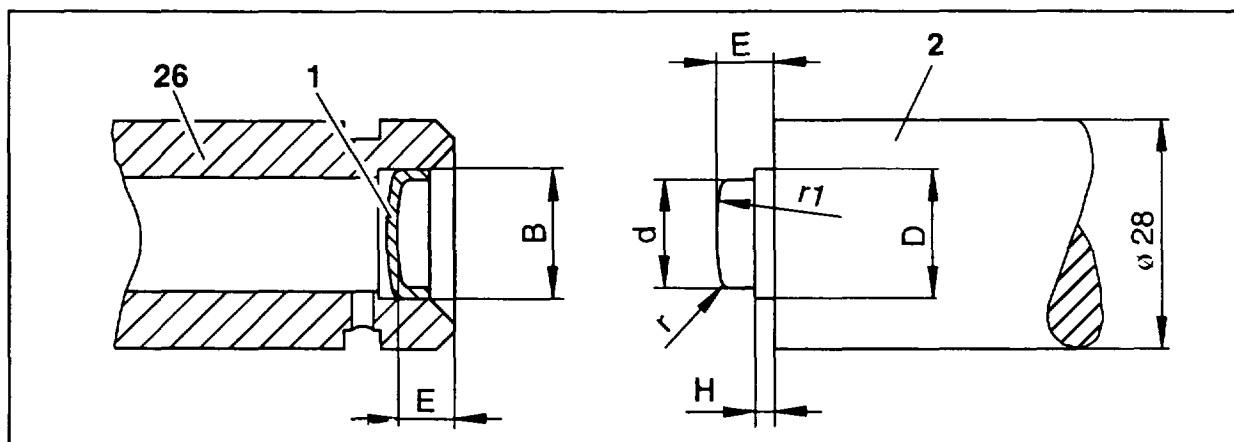

P05-5507-53

Cap (1)	press out with a screwdriver
Hollow-drilled camshaft (26)	clean
Hole (B)	check (see table for sizes)
End cover (1)	knock in with drift (2) (shop-made tool)



Use new end cover (1). The end cover (1) must not sit at the end of the hole. It is important to adhere to the insertion depth (size E).

Data in mm

Camshaft (26)	1st version	2nd version	
Hole (B)	18.00 – 18.04	14.00 – 14.04	
End cover DIN 443 (1)	A18	A14	
Insertion depth size (E)	10.0	9.3	
Insertion drift (2) (shop-made tool) sizes	d	15.7	11.7
	D	17.7	13.7
	H	5.3	4.3
	r	1	1
	r1	45	35

