

01-4200 Pressure-testing cylinder head

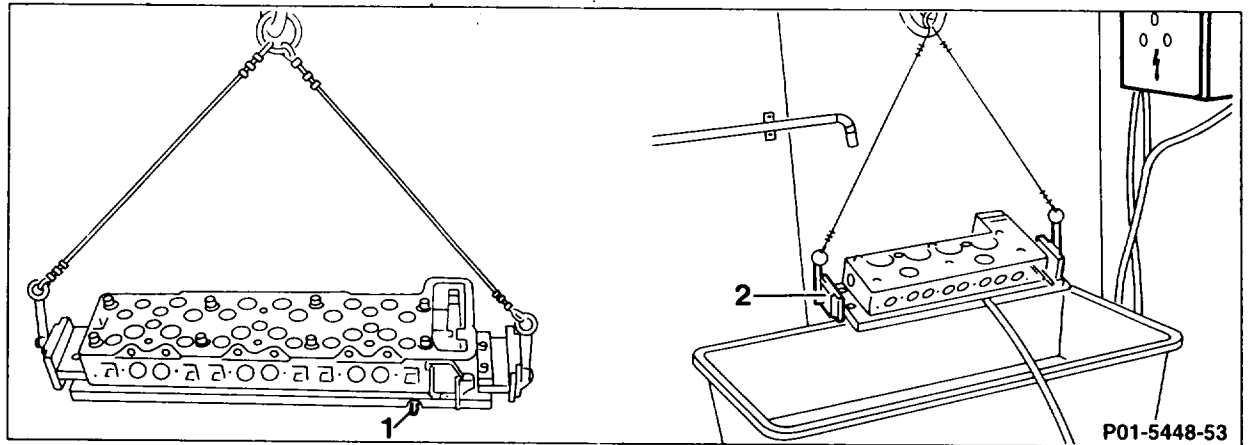

Cleaned cylinder head	fit onto pressure-testing plate (1).
Coolant passages at front and rear	seal.
Compressed air hose	connect.
Cylinder head	pressurize, (2 bar).
Cylinder head	attach to lifting device (2).
Cylinder head	immerse in tank of water heated to 80 °C.
If air bubbles rise up	determine leak points, mark.

Special tools

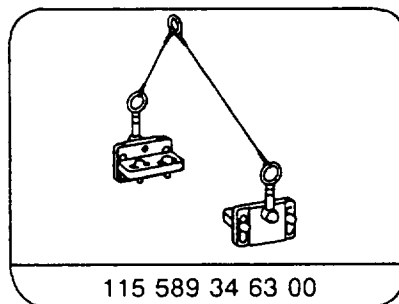
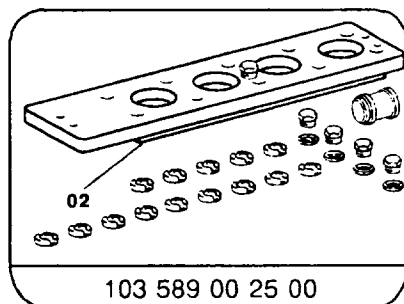

Commercially available tool

Electrically heated water tank

eg. Edelstahlbau Hessenthal GmbH
D-74532 Schwäbisch Hall