

47-020 Function of fuel gauge Sending unit - Turbodiesel

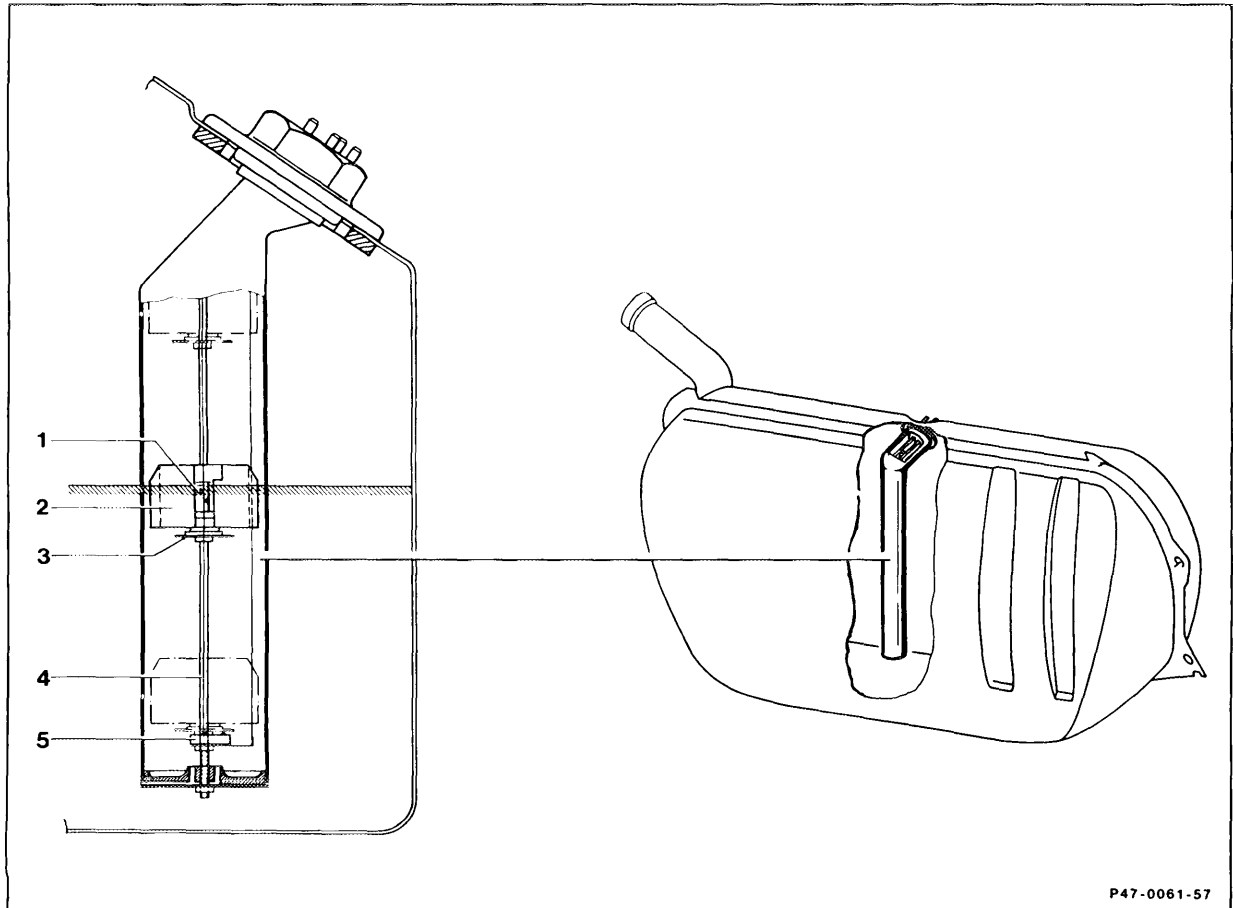

1 Wiper contact
2 Float
3 Contact plate

4 Guide and contact rod
5 Reserve fuel warning circuit

If the fuel level drops, the resistance is increased by the wiper contact (1) on the float (2), the voltage drops and the needle on the gauge in the instrument cluster moves back.

If the fuel level drops to reserve quantity, the reserve warning contact (5) closes and switches ground to the reserve warning lamp. The reserve warning lamp lights up if the ignition is switched on (indicating function). As soon as the engine is running, it goes out provided there is more fuel in the tank than the reserve quantity.

Note

The reserve fuel warning lamp shows a weaker light for the indicating function and a stronger light for the reserve quantity.

Check fuel gauge (54-257).