

47-020 Function of fuel gauge sending unit

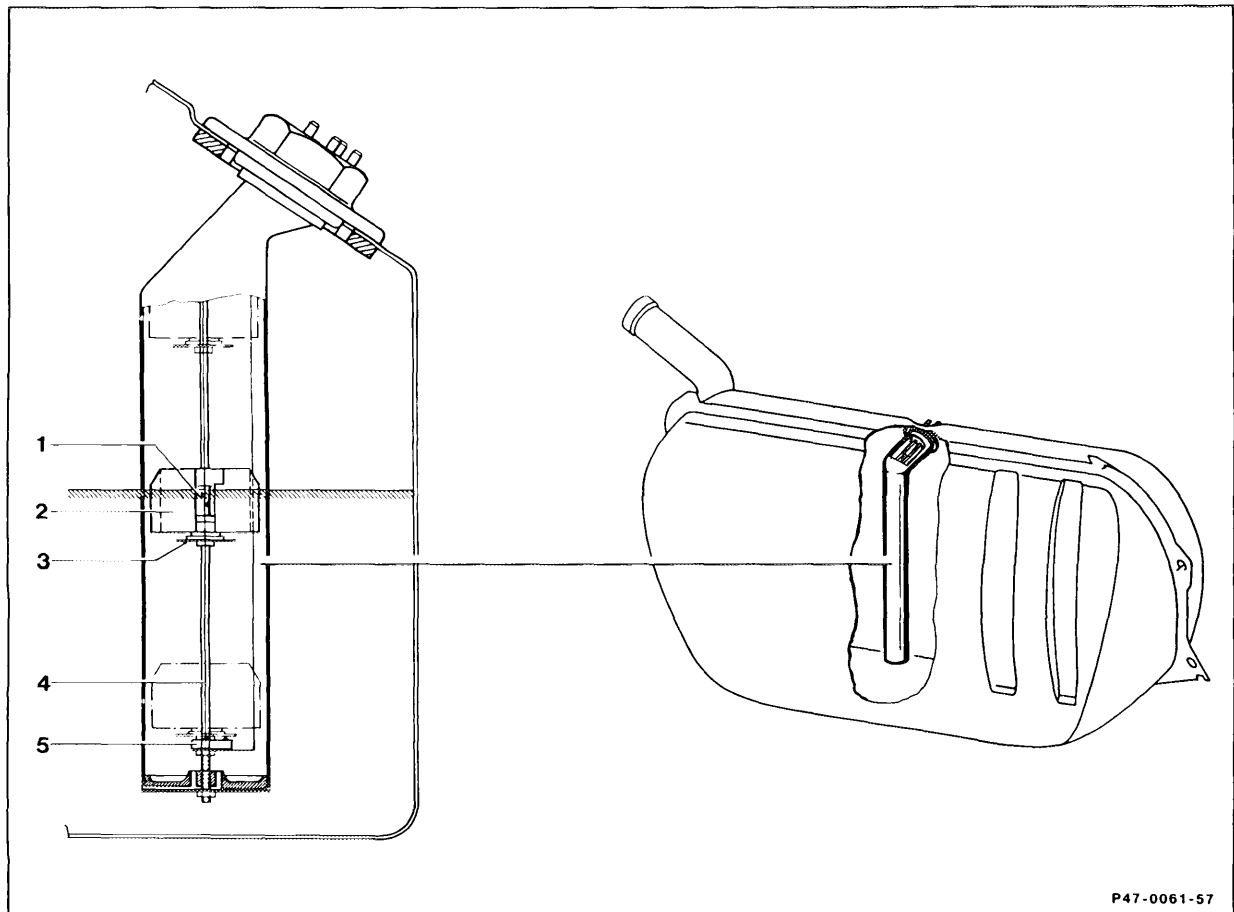

- 1 Wiper contact
- 2 Float
- 3 Contact plate
- 4 Guide and contact rod
- 5 Reserve warning contact

As the fuel level drops, the resistance is increased by the wiper contact (1). At the float (2), the voltage drops and the gauge needle in the instrument cluster moves back.

If the fuel level drops to the reserve quantity, the reserve warning contact (5) closes and switches ground to the reserve warning lamp. The reserve warning lamp lights up when the ignition is switched on (check function).

As soon as the engine starts, the lamp goes out provided there is more fuel in the tank than the reserve quantity.

Note

The reserve warning lamp shows a weaker light for the check function, and a stronger light to indicate reserve quantity.

Check fuel gauge (54-269).

Fuel gauge sending unit, Model 201

The installation angle has been modified from approx. 15° (off perpendicular) to approx. 5°. The instrument gauge has been adapted to the new sending unit position (refer to Group 54).

Repair instructions

The modified sending unit (5°) may also be fitted in place of the existing sending unit (15°), but not vice versa.

Standard implementation: July 1987

Vehicle ident No.

A 394 178

F 390 243

Modifications effective 09/88 (Model Care)

The fuel gauge sending unit has been modified at the flange and in its length such that it is valid for all fuel tanks of Model 201 effective 09/88.