

## 05-437 Removal and installation of pressure oil pump drive

Preceding work:  
Charge air pipe removed (turbo engines).

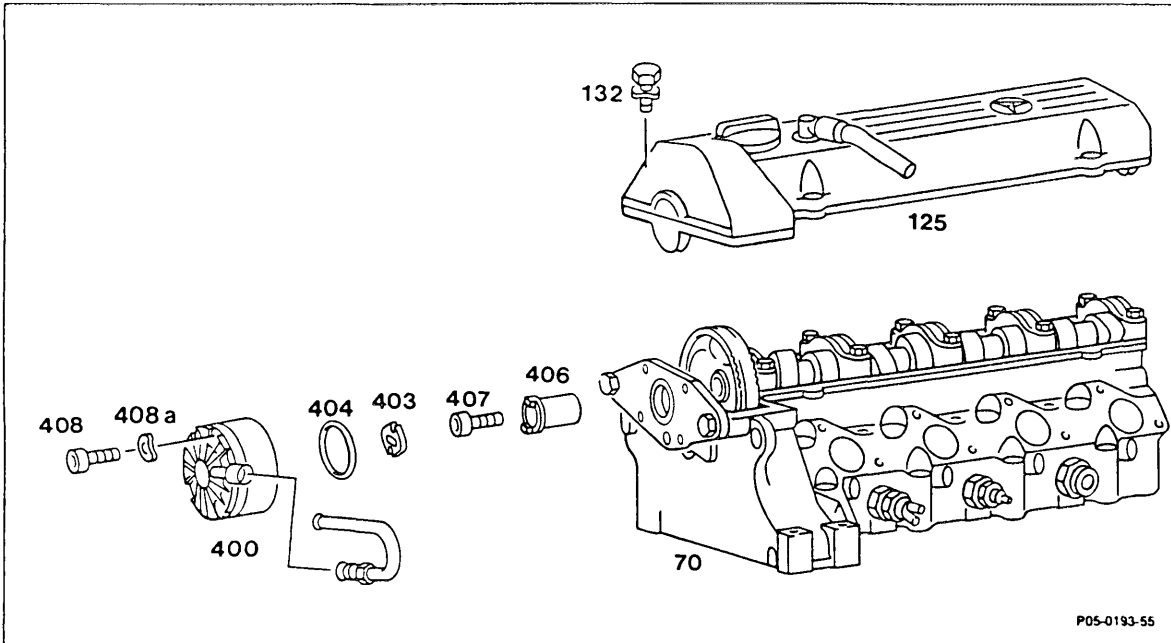

Cylinder head cover (125) .....	remove, install, fixing bolt (132), 10 Nm.
Pressure oil pump (400) .....	unbolt, reinstall, fixing bolt (408) with washers (408a), 11 Nm, put pressure oil pump to one side with lines connected.

### Note

Do not unbolt the upper and lower bolt with continuous thread (visible between housing and cover).

O-ring (404) .....	replace.
Carrier (403) .....	remove, install, check.
Bolt (407) .....	unbolt, reinstall. Note different bolt (05-220). Tightening torque and angle of rotation Hexagon bolt 25 Nm, Bihexagonal necked down bolt 25 Nm, 90°.
Carrier sleeve (406) .....	remove, install. Use grease when installing. Note different design (05-220).

**Note**

Since 11/88 the camshaft timing gear has been fitted with a bihexagonal necked down bolt M11 (previously hexagon bolt M10). The carrier has been revised as a result of this change.

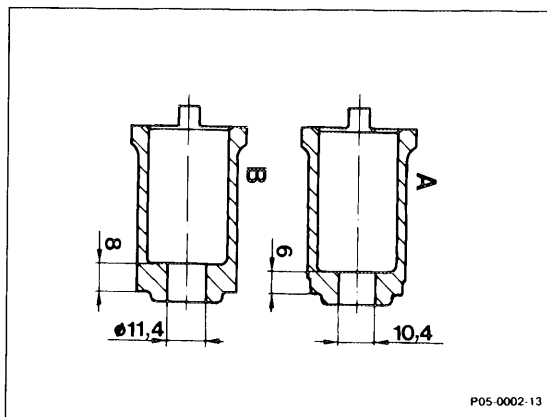

A Previous Design  
 B Revised Design

**Production breakpoint: 11/88**

Model	Engine	Engine end No.		Vehicle identification end No.	
		Manual transmission	Automatic transmission	A	F
124	602.962	-	000187	*	*
	603.960	-	019336		
	603.963				
201	602.911	070124	014216	*	*
	602.961	-	004561		

\* not recorded

**Special tool**

