

## 01-222 Removal and installation of end cover

---

Preliminary operations:  
Flywheel removed (03-410).

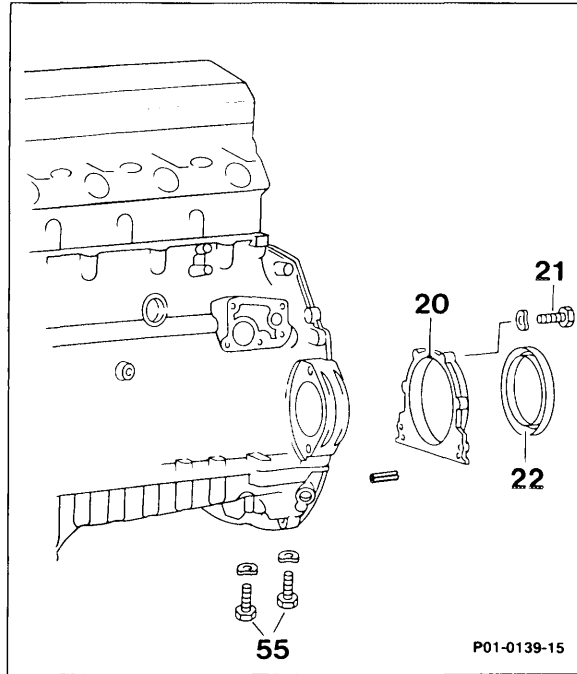

- |                            |  |
|----------------------------|--|
| Hex. head bolts (55) ..... | in oil pan, remove, reinstall, 25 Nm (item 1).                             |
| Hex. head bolts (21) ..... | Hex. head bolts (21) in end cover (20), remove, reinstall, 10 Nm (item 2). |

### Note

Coat threads of hex. head bolts with sealant 002 989 20 10.

End cover (20) ..... press out together with crankshaft radial seal (22), press in, installation sleeve 601 589 03 43 00 (item 3).

**Note**

Avoid damaging oil pan gasket.

**Note**

Clean gasket residues off of parting surface on end cover and coat parting surface of cap with sealant 002 989 00 20 10. Check crankshaft radial seal and remove if required, install, installation sleeve 601 589 03 43 00.

**Sealant**

Omnifit	002 989 00 20 10
---------	------------------

**Tightening torques**

	Nm
Hex. head bolts, end cover	10
Hex. head bolts, oil pan	25

**Special tools**

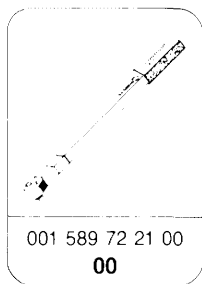
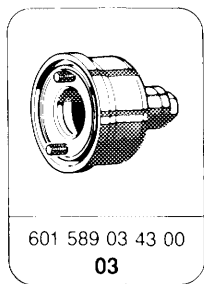

## Removal, installation

1 Remove the two hex. head bolts (55) in the oil pan.

### Installation note

Tightening torque 25 Nm.

2 Remove hex. head bolts (21) in end cover (20).

### Installation note

Coat threads on hex. head bolts with sealant 002 989 00 20 10.

Tightening torque 10 Nm.

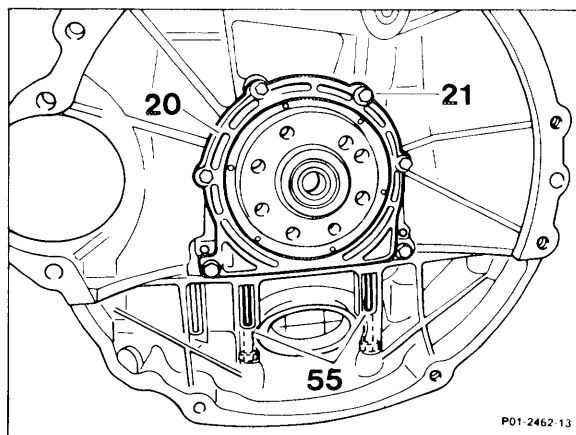

3 Press end cover off of crankcase at tabs (arrows) and remove crankshaft radial seal from crankshaft journal.

### Note

When pressing the end cover on and off avoid damaging the oil pan gasket. .

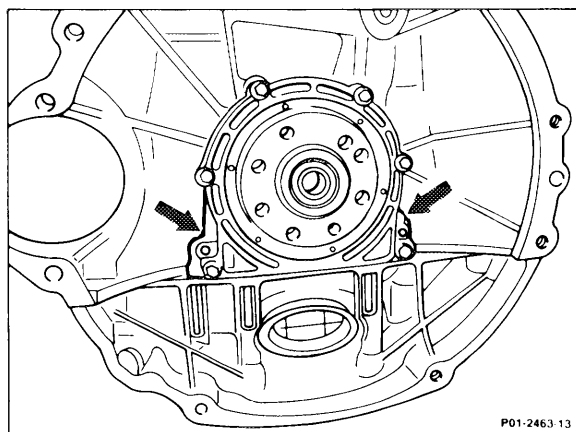

### Installation note

Clean gasket residues off of parting surface on end cover. Check crankshaft radial seal and replace if required. Coat parting surface on end cover with sealant 002 989 00 20 10 and slide end cover together with radial seal over attached installation sleeve 601 589 03 43 00.

