

- Picture -

Mode : MDmode

FIN/MD : 124031

Catalog no. : 15S

VIN :

Major assembly :

Salesdesignation: 300E-24,AMG300E3.4

Major assembly MD :

Assortment class : Car

Group : 35 - REAR AXLE

Market : Europe

Subgroup : 015 - REAR AXLE HOUSING WITH DIFFERENTIAL

Picture number : B35015000017.950516

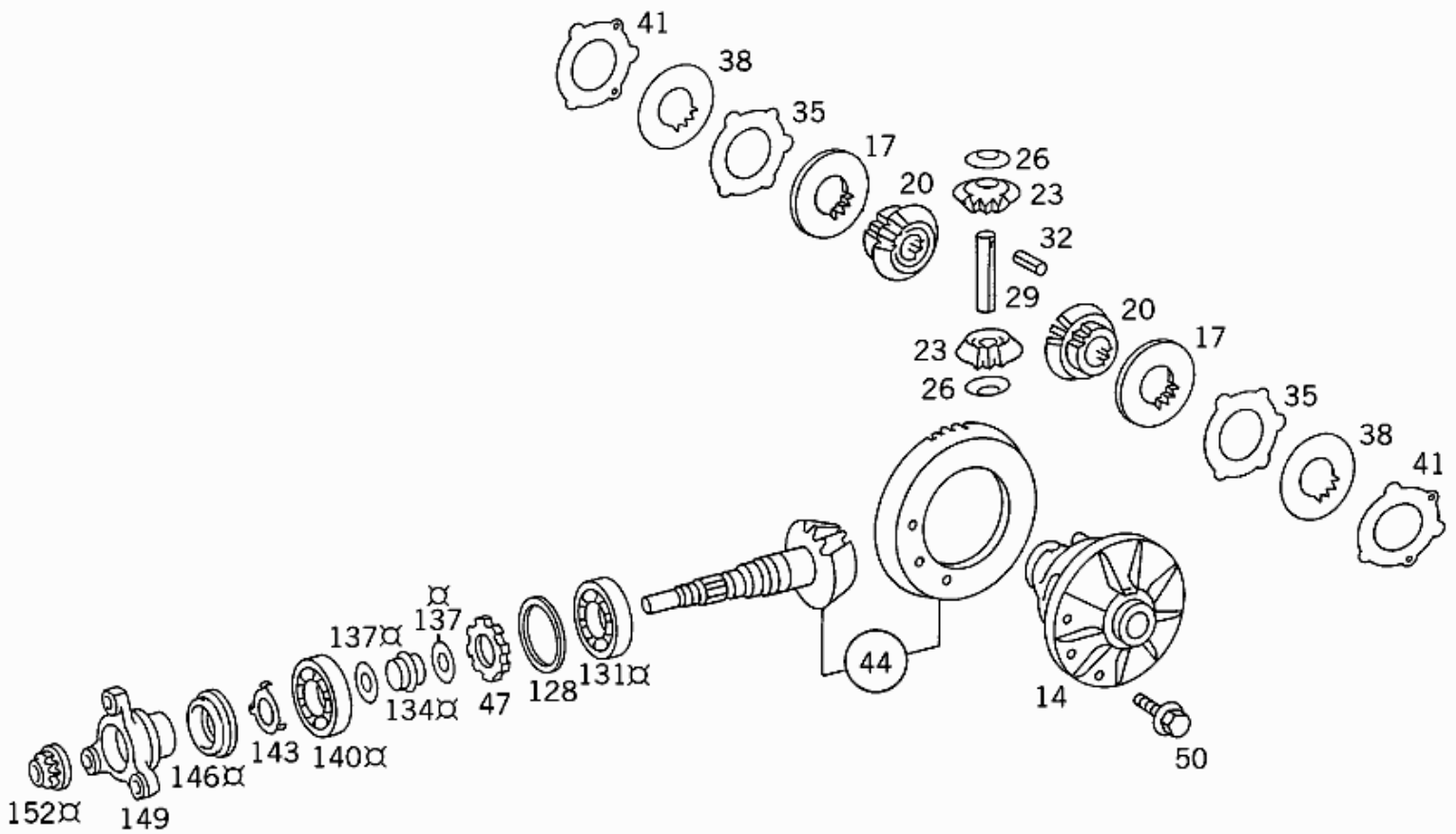

- Parts list -

Mode :	MD mode	FIN/MD :	124031
Catalog no. :	15S	VIN :	
Major assembly :		Sales designation :	300 E-24, AMG 300 E 3.4
Major assembly MD :		Assortment class :	Car
Group :	35 - REAR AXLE	Market :	Europe
Subgroup :	015 - REAR AXLE HOUSING WITH DIFFERENTIAL		

Item no.	Part number	Designation/description	Quantity	Version
5	A 124 350 79 14	<b>HOUSING</b> REAR AXLE HOUSING WITH DIFFERENTIAL; MAN. 5-SPEED/AUTO 4-SPEED TRANSMISSION ABS 1:3.27 ☐ [697] PART IS ONLY OR ALSO SUPPLIED AS RECONDITIONED PART	001	
5	A 124 350 81 14	<b>HOUSING</b> REAR AXLE HOUSING WITH DIFFERENTIAL, AUTOMATIC FIVE-SPEED TRANSMISSION ABS 1:3.69	001	
5	A 124 350 83 14	<b>HOUSING</b> REAR AXLE HOUSING WITH DIFFERENTIAL; MAN. 5-SPEED/AUTO 4-SPEED TRANSMISSION ASD 1:3.27 ☐ [100, 697] PLEASE MIND MODIFIED ARRANGEMENT OF LINES	001	
5	A 124 350 85 14	<b>HOUSING</b> REAR AXLE HOUSING WITH DIFFERENTIAL, AUTOMATIC FIVE-SPEED TRANSMISSION ASD 1:3.69 ☐ [697] PART IS ONLY OR ALSO SUPPLIED AS RECONDITIONED PART	001	
5	A 124 350 88 14	<b>HOUSING</b> REAR AXLE HOUSING WITH DIFFERENTIAL ASR 1:3.27 ☐ [697] PART IS ONLY OR ALSO SUPPLIED AS RECONDITIONED PART	001	A
5	A 124 350 89 14	<b>HOUSING</b> REAR AXLE HOUSING WITH DIFFERENTIAL, AUTOMATIC FIVE-SPEED TRANSMISSION ASR 1:3.69 ☐ [697] PART IS ONLY OR ALSO SUPPLIED AS RECONDITIONED PART	001	A
8	A 129 351 04 05	<b>HOUSING</b> USED WITHOUT W/ACCELERATION SKID CONTROL (ASR)	001	
8	A 129 351 05 05	<b>HOUSING</b> ONLY USED W/ACCELERATION SKID CONTROL (ASR)	001	
11	A 186 997 00 32	<b>SCREW PLUG</b>	002	
14	A 140 350 27 23	<b>DIFFERENTIAL GEAR</b> LESS RING GEAR AND PINION ☐ [003] USED WITHOUT AUTOMATIC LOCKING DIFFERENTIAL (ASD)	001	
14	A 140 350 29 23	<b>DIFFERENTIAL GEAR</b> LESS RING GEAR AND PINION ☐ [004] ONLY USED WITH AUTOMATIC LOCKING DIFFERENTIAL (A S D)	001	
<b>BREAK-DOWN OF DIFFERENTIAL GEAR</b>				
17	A 184 353 00 62	<b>THRUST WASHER</b> AS REQUIRED 1.30 MM ☐ [003] USED WITHOUT AUTOMATIC LOCKING DIFFERENTIAL (ASD)	002	
17	A 108 353 01 62	<b>THRUST WASHER</b> AS REQUIRED 1.35 MM ☐ [003] USED WITHOUT AUTOMATIC LOCKING DIFFERENTIAL (ASD)	002	
<b>THRUST WASHER</b>				

17	A 184 353 01 62	<b>THRUST WASHER</b> AS REQUIRED 1.40 MM <input type="checkbox"/> [003] USED WITHOUT AUTOMATIC LOCKING DIFFERENTIAL (ASD)	002
17	A 108 353 02 62	<b>THRUST WASHER</b> AS REQUIRED 1.45 MM <input type="checkbox"/> [003] USED WITHOUT AUTOMATIC LOCKING DIFFERENTIAL (ASD)	002
17	A 184 353 02 62	<b>THRUST WASHER</b> AS REQUIRED 1.50 MM <input type="checkbox"/> [003] USED WITHOUT AUTOMATIC LOCKING DIFFERENTIAL (ASD)	002
17	A 108 353 03 62	<b>THRUST WASHER</b> AS REQUIRED 1.55 MM <input type="checkbox"/> [003] USED WITHOUT AUTOMATIC LOCKING DIFFERENTIAL (ASD)	002
17	A 184 353 03 62	<b>THRUST WASHER</b> AS REQUIRED 1.60 MM <input type="checkbox"/> [003] USED WITHOUT AUTOMATIC LOCKING DIFFERENTIAL (ASD)	002
17	A 108 353 04 62	<b>THRUST WASHER</b> AS REQUIRED 1.65 MM <input type="checkbox"/> [003] USED WITHOUT AUTOMATIC LOCKING DIFFERENTIAL (ASD)	002
17	A 184 353 04 62	<b>THRUST WASHER</b> AS REQUIRED 1.70 MM <input type="checkbox"/> [003] USED WITHOUT AUTOMATIC LOCKING DIFFERENTIAL (ASD)	002
17	A 129 353 10 62	<b>THRUST WASHER</b> AS REQUIRED 2.8 MM <input type="checkbox"/> [002, 004] WITH LINING ON ONE SIDE	002
17	A 129 353 09 62	<b>THRUST WASHER</b> AS REQUIRED 2.9 MM <input type="checkbox"/> [002, 004] WITH LINING ON ONE SIDE	002
17	A 129 353 08 62	<b>THRUST WASHER</b> AS REQUIRED 3 MM <input type="checkbox"/> [002, 004] WITH LINING ON ONE SIDE	002
17	A 129 353 07 62	<b>THRUST WASHER</b> AS REQUIRED 3.1 MM <input type="checkbox"/> [002, 004] WITH LINING ON ONE SIDE	002
17	A 129 353 06 62	<b>THRUST WASHER</b> AS REQUIRED 3.2 MM <input type="checkbox"/> [002, 004] WITH LINING ON ONE SIDE	002
17	A 129 353 05 62	<b>THRUST WASHER</b> AS REQUIRED 3.3 MM <input type="checkbox"/> [002, 004] WITH LINING ON ONE SIDE	002
17	A 129 353 04 62	<b>THRUST WASHER</b> AS REQUIRED 3.4 MM <input type="checkbox"/> [002, 004] WITH LINING ON ONE SIDE	002
17	A 129 353 03 62	<b>THRUST WASHER</b> AS REQUIRED 3.5 MM <input type="checkbox"/> [002, 004] WITH LINING ON ONE SIDE	002
17	A 129 353 02 62	<b>THRUST WASHER</b> AS REQUIRED 3.6 MM <input type="checkbox"/> [002, 004] WITH LINING ON ONE SIDE	002
17	A 129 353 01 62	<b>THRUST WASHER</b> AS REQUIRED 4.0 MM <input type="checkbox"/> [002, 004] WITH LINING ON ONE SIDE	002
20	A 140 353 07 15	<b>SIDE GEAR</b> USED WITHOUT AUTOMATIC LOCKING DIFFERENTIAL (ASD)	002
20	A 140 353 08 15	<b>SIDE GEAR</b> ONLY USED WITH ASD	002
23	A 140 353 05 14	<b>DIFFERENTIAL PINION</b>	002
26	A 140 353 01 24	<b>SPHERICAL WASHER</b>	002
29	A 126 353 08 21	<b>PIN</b>	001
32	N 001481 006008	<b>CLAMPING SLEEVE</b>	001
35	A 112 353 06 62	<b>THRUST WASHER</b> LESS LINING; WITH 5 SHACKLES <input type="checkbox"/> [004] ONLY USED WITH AUTOMATIC LOCKING DIFFERENTIAL (A S D)	010
38	A 129 353 11 62	<b>THRUST WASHER</b> WITH LINING ON BOTH SIDES <input type="checkbox"/> [004] ONLY USED WITH AUTOMATIC LOCKING DIFFERENTIAL (A S D)	008

44	A 126 350 24 39	<b>RING GEAR AND PINION</b> 1:3,27 ☐ [130] FOR ASD OR 4-MATIC USE REAR AXLE OIL A 001 989 17 03	001
44	A 129 350 06 39	<b>RING GEAR AND PINION</b> AUTOMATIC FIVE-SPEED TRANSMISSION 1:3.69 ☐ [130] FOR ASD OR 4-MATIC USE REAR AXLE OIL A 001 989 17 03	001
47	A 126 353 00 85	<b>GEAR</b> 29 TEETH 1:3.27 ☐ [005] FOR USE WITHOUT ACCELERATION SKID CONTROL (A S R)	001
47	A 123 353 03 85	<b>GEAR</b> 26 TEETH 1:3.69 ☐ [005] FOR USE WITHOUT ACCELERATION SKID CONTROL (A S R)	001
50	A 140 990 21 01	<b>SCREW</b> RING GEAR TO DIFFERENTIAL CASE	010
		<b>DIFFERENTIAL GEAR BEARING HAG 168</b>	
		<b>DIFFERENTIAL GEAR BEARING HAG 185</b>	
		<b>DIFFERENTIAL GEAR BEARING 210</b>	
80	A 000 980 19 02	<b>TAPERED ROLLER BEARING</b> RING GEAR BEARING	002
83	A 116 353 14 52	<b>SPACER WASHER</b> AS REQUIRED 0.90 MM	002
83	A 116 353 16 52	<b>SPACER WASHER</b> AS REQUIRED 1.00 MM	002
83	A 116 353 17 52	<b>SPACER WASHER</b> AS REQUIRED 1.05 MM	002
83	A 116 353 18 52	<b>SPACER WASHER</b> AS REQUIRED 1.10 MM	002
83	A 116 353 19 52	<b>SPACER WASHER</b> AS REQUIRED 1.15 MM	002
83	A 116 353 38 52	<b>SPACER WASHER</b> AS REQUIRED 1.20 MM	002
83	A 116 353 39 52	<b>SPACER WASHER</b> AS REQUIRED 1.30 MM	002
83	A 116 353 40 52	<b>SPACER WASHER</b> AS REQUIRED 1.40 MM	002
83	A 116 353 41 52	<b>SPACER WASHER</b> AS REQUIRED 1.45 MM	002
83	A 116 353 42 52	<b>SPACER WASHER</b> AS REQUIRED 1.50	002
83	A 116 353 43 52	<b>SPACER WASHER</b> AS REQUIRED 1.55 MM	002
83	A 116 353 44 52	<b>SPACER WASHER</b> AS REQUIRED 1.60 MM	002
83	A 116 353 45 52	<b>SPACER WASHER</b> AS REQUIRED 1.70 MM	002
83	A 116 353 46 52	<b>SPACER WASHER</b> AS REQUIRED 1.80 MM	002
83	A 116 353 47 52	<b>SPACER WASHER</b> AS REQUIRED 1.90 MM	002
83	A 116 353 48 52	<b>SPACER WASHER</b> AS REQUIRED 2.00 MM	002
83	A 116 353 49 52	<b>SPACER WASHER</b> AS REQUIRED 2.10 MM	002
83	A 116 353 50 52	<b>SPACER WASHER</b> AS REQUIRED 2.20 MM	002
83	A 116 353 51 52	<b>SPACER WASHER</b> AS REQUIRED 2.30 MM	002
83	A 116 353 52 52	<b>SPACER WASHER</b> AS REQUIRED 2.40 MM	002
83	A 116 353 53 52	<b>SPACER WASHER</b> AS REQUIRED 2.50 MM	002
83	A 116 353 54 52	<b>SPACER WASHER</b> AS REQUIRED 2.60 MM	002
86	A 126 353 01 06	<b>COVER</b> BEARING COVER ☐ [003, 005] USED WITHOUT AUTOMATIC LOCKING DIFFERENTIAL (ASD)	002

86	A 126 353 04 06	<b>COVER</b> BEARING COVER ☐ [006] ONLY USED W/ACCELERATION SKID CONTROL (A S R)	002
86	A 129 350 05 02	<b>COVER</b> BEARING COVER,LEFT ☐ [004] ONLY USED WITH AUTOMATIC LOCKING DIFFERENTIAL (A S D)	001
86	A 129 350 06 02	<b>COVER</b> BEARING COVER,RIGHT ☐ [004] ONLY USED WITH AUTOMATIC LOCKING DIFFERENTIAL (A S D)	001
89	A 124 353 00 89	<b>BOOT</b> BEARING COVER ☐ [004] ONLY USED WITH AUTOMATIC LOCKING DIFFERENTIAL (A S D)	002
92	A 003 997 25 48	<b>SEAL RING</b> BEARING COVER TO AXLE HOUSING	002
95	N 000912 008012	<b>SCREW</b> BEARING COVER TO AXLE HOUSING	016
98	A 000 353 08 56	<b>VALVE</b> <b>Replaced by:</b> A 000 353 09 56 +002 A 000 421 26 87	-
98	A 000 353 09 56	<b>VALVE</b> BLEEDER VALVE ☐ [004] ONLY USED WITH AUTOMATIC LOCKING DIFFERENTIAL (A S D)	001
101	A 000 421 08 87	<b>PROTECTIVE CAP</b> ☐ [004] ONLY USED WITH AUTOMATIC LOCKING DIFFERENTIAL (A S D)	001
104	A 020 997 25 47	<b>SEAL RING</b> INTERIOR FLANGE ☐ [003, 005] USED WITHOUT AUTOMATIC LOCKING DIFFERENTIAL (ASD)	002
104	A 014 997 57 47	<b>SEAL RING</b> INTERIOR FLANGE ☐ [004] ONLY USED WITH AUTOMATIC LOCKING DIFFERENTIAL (A S D)	002
104	A 014 997 72 47	<b>SEAL RING</b> INTERIOR FLANGE ☐ [006] ONLY USED W/ACCELERATION SKID CONTROL (A S R)	002
105	A 124 350 53 98	<b>REPAIR KIT</b> MOUNTING PARTS	001
107	A 129 350 08 45	<b>INTERIOR FLANGE</b> <b>FLANGE</b> INSIDE ☐ [003, 005] USED WITHOUT AUTOMATIC LOCKING DIFFERENTIAL (ASD)	002
107	A 124 350 58 45	<b>FLANGE</b> INSIDE ☐ [004] ONLY USED WITH AUTOMATIC LOCKING DIFFERENTIAL (A S D)	002
107	A 129 350 09 45	<b>FLANGE</b> INSIDE ☐ [006] ONLY USED W/ACCELERATION SKID CONTROL (A S R)	002
113	A 004 981 71 25	<b>BALL BEARING</b> ☐ [004] ONLY USED WITH AUTOMATIC LOCKING DIFFERENTIAL (A S D)	002
116	A 115 357 76 52	<b>SPACER WASHER</b> AS REQUIRED 2.60 MM ☐ [003] USED WITHOUT AUTOMATIC LOCKING DIFFERENTIAL (ASD)	002
116	A 124 357 21 52	<b>SPACER WASHER</b> AS REQUIRED 2,65 MM	002
116	A 115 357 75 52	<b>SPACER WASHER</b> AS REQUIRED 2.70 MM ☐ [003] USED WITHOUT AUTOMATIC LOCKING DIFFERENTIAL (ASD)	002
116	A 124 357 22 52	<b>SPACER WASHER</b> AS REQUIRED 2,75 MM	002
116	A 115 357 74 52	<b>SPACER WASHER</b> AS REQUIRED 2.80 MM ☐ [003] USED WITHOUT AUTOMATIC LOCKING DIFFERENTIAL (ASD)	002
116	A 124 357 23 52	<b>SPACER WASHER</b> AS REQUIRED 2,85 MM	002
116	A 115 357 64 52	<b>SPACER WASHER</b> AS REQUIRED 2.90 MM ☐ [003] USED WITHOUT AUTOMATIC LOCKING DIFFERENTIAL (ASD)	002

116	A 115 357 63 52	<b>SPACER WASHER</b> AS REQUIRED 2.95 MM ☐ [003] USED WITHOUT AUTOMATIC LOCKING DIFFERENTIAL (ASD)	002
116	A 115 357 62 52	<b>SPACER WASHER</b> AS REQUIRED 3.00 MM ☐ [003] USED WITHOUT AUTOMATIC LOCKING DIFFERENTIAL (ASD)	002
116	A 115 357 61 52	<b>SPACER WASHER</b> AS REQUIRED 3.05 MM ☐ [003] USED WITHOUT AUTOMATIC LOCKING DIFFERENTIAL (ASD)	002
116	A 115 357 60 52	<b>SPACER WASHER</b> AS REQUIRED 3.10 MM ☐ [003] USED WITHOUT AUTOMATIC LOCKING DIFFERENTIAL (ASD)	002
116	A 115 357 59 52	<b>SPACER WASHER</b> AS REQUIRED 3.15 MM ☐ [003] USED WITHOUT AUTOMATIC LOCKING DIFFERENTIAL (ASD)	002
116	A 115 357 58 52	<b>SPACER WASHER</b> AS REQUIRED 3.20 MM ☐ [003] USED WITHOUT AUTOMATIC LOCKING DIFFERENTIAL (ASD)	002
116	A 115 357 57 52	<b>SPACER WASHER</b> AS REQUIRED 3.25 MM ☐ [003] USED WITHOUT AUTOMATIC LOCKING DIFFERENTIAL (ASD)	002
116	A 115 357 56 52	<b>SPACER WASHER</b> AS REQUIRED 3.30 MM ☐ [003] USED WITHOUT AUTOMATIC LOCKING DIFFERENTIAL (ASD)	002
116	A 115 357 55 52	<b>SPACER WASHER</b> AS REQUIRED 3.35 MM ☐ [003] USED WITHOUT AUTOMATIC LOCKING DIFFERENTIAL (ASD)	002
116	A 115 357 54 52	<b>SPACER WASHER</b> AS REQUIRED 3.40 MM ☐ [003] USED WITHOUT AUTOMATIC LOCKING DIFFERENTIAL (ASD)	002
119	A 115 994 04 34	<b>SNAP RING</b> <b>(SHIM) ASR SENSOR TO REAR AXLE HOUSING</b>	002
122	A 126 351 02 76	<b>SHIM</b> AS REQUIRED 1.0 MM	002
122	A 126 351 03 76	<b>SHIM</b> AS REQUIRED 1.1 MM	002
122	A 126 351 04 76	<b>SHIM</b> AS REQUIRED 1.2 MM	002
122	A 126 351 05 76	<b>SHIM</b> AS REQUIRED 1.3 MM	002
122	A 126 351 06 76	<b>SHIM</b> AS REQUIRED 1.4 MM	002
122	A 126 351 07 76	<b>SHIM</b> AS REQUIRED 1.5 MM	002
122	A 126 351 08 76	<b>SHIM</b> AS REQUIRED 1.6 MM	002
122	A 126 351 09 76	<b>SHIM</b> AS REQUIRED 1.7 MM	002
122	A 126 351 10 76	<b>SHIM</b> AS REQUIRED 1.8 MM	002
122	A 126 351 11 76	<b>SHIM</b> AS REQUIRED 1.9 MM	002
122	A 126 351 12 76	<b>SHIM</b> AS REQUIRED 2.0 MM	002
122	A 126 351 13 76	<b>SHIM</b> AS REQUIRED 2,1 MM	002
122	A 126 351 14 76	<b>SHIM</b> AS REQUIRED 2,2 MM	002
122	A 126 351 15 76	<b>SHIM</b> AS REQUIRED 2,3 MM	002
125	A 126 989 01 85	<b>ADHESIVE TAPE</b> <b>DRIVE PINION BEARING</b>	002
128	A 116 353 11 52	<b>SPACER WASHER</b> AS REQUIRED 1.50 MM	001
128	A 116 353 20 52	<b>SPACER WASHER</b> AS REQUIRED 1.55 MM	001

128	A 116 353 21 52	<b>SPACER WASHER</b> AS REQUIRED 1.60 MM	001
128	A 116 353 22 52	<b>SPACER WASHER</b> AS REQUIRED 1.65 MM	001
128	A 116 353 23 52	<b>SPACER WASHER</b> AS REQUIRED 1.70 MM	001
128	A 116 353 24 52	<b>SPACER WASHER</b> AS REQUIRED 1.75 MM	001
128	A 116 353 25 52	<b>SPACER WASHER</b> AS REQUIRED 1.80 MM	001
128	A 116 353 26 52	<b>SPACER WASHER</b> AS REQUIRED 1.85 MM	001
128	A 116 353 27 52	<b>SPACER WASHER</b> AS REQUIRED 1.90 MM	001
128	A 116 353 28 52	<b>SPACER WASHER</b> AS REQUIRED 1.95 MM	001
128	A 116 353 29 52	<b>SPACER WASHER</b> AS REQUIRED 2.00 MM	001
128	A 116 353 30 52	<b>SPACER WASHER</b> AS REQUIRED 2.05 MM	001
128	A 116 353 31 52	<b>SPACER WASHER</b> AS REQUIRED 2.10 MM ☐ [402] NO LONGER AVAILABLE	001
128	A 116 353 32 52	<b>SPACER WASHER</b> AS REQUIRED 2.15 MM	001
128	A 116 353 33 52	<b>SPACER WASHER</b> AS REQUIRED 2.20 MM	001
128	A 116 353 34 52	<b>SPACER WASHER</b> AS REQUIRED 2.25 MM	001
128	A 116 353 35 52	<b>SPACER WASHER</b> AS REQUIRED 2.30 MM	001
128	A 116 353 36 52	<b>SPACER WASHER</b> AS REQUIRED 2.35 MM	001
128	A 116 353 37 52	<b>SPACER WASHER</b> AS REQUIRED 2.40 MM	001
131	A 000 980 84 02	<b>TAPERED ROLLER BEARING</b> DRIVE PINION	001
134	A 108 353 00 42	<b>SPACER BUSHING</b>	001
137	A 109 353 10 62	<b>THRUST WASHER</b>	002
140	A 002 980 11 02	<b>TAPERED ROLLER BEARING</b> DRIVE PINION	001
143	A 126 353 07 62	<b>THRUST WASHER</b>	001
146	A 022 997 99 47	<b>SEAL RING</b> DRIVE PINION	001
149	A 124 350 65 45	<b>FLANGE</b> <b>Replaced by:</b> A 211 350 01 45 +002 A 022 997 99 47	-
149	A 211 350 01 45	<b>FLANGE</b> <b>Replaced by:</b> A 211 350 02 45 +001 A 025 997 00 47	-
149	A 211 350 02 45	<b>FLANGE</b> PROPELLER SHAFT 100 MM	001
152	A 123 353 00 72	<b>NUT</b> <b>COVER</b>	001
155	A 124 350 00 21	<b>Replaced by:</b> A 124 350 01 21 +008 A 000 990 32 04 ☐ [030] Up to ident. no.: B841262,J 002476	-
155	A 124 350 01 21	<b>COVER</b> <b>Replaced by:</b> A 124 351 34 08 ☐ [031] As of ident. no. B841263,J 002477	-
155	A 124 351 34 08	<b>COVER</b> END COVER ☐ [031] As of ident. no. B841263,J 002477	001
158	N 304017 010040	<b>SCREW</b> ☐ [030] Up to ident. no.: B841262,J 002476	008
158	A 000 990 32 04	<b>SCREW</b> <b>Replaced by:</b> N 910143 010009 ☐ [031] As of ident. no. B841263,J 002477	-

158	N 910143 010009	<b>SCREW</b> [031] As of ident. no. B841263,J 002477	008
161	N 000137 010205	<b>SPRING WASHER</b> [030] Up to ident. no.: B841262,J 002476	008
164	A 124 584 58 17	<b>GUIDE SIGN</b> LIMITED-SLIP DIFFERENTIAL [003] USED WITHOUT AUTOMATIC LOCKING DIFFERENTIAL (ASD)	001
167	A 126 350 00 90	<b>VALVE</b>	001
173	A 129 350 01 84	<b>GASKET KIT</b> O-RINGS [004] ONLY USED WITH AUTOMATIC LOCKING DIFFERENTIAL (A S D)	002
176	A 124 350 03 74	<b>REPAIR KIT</b> REAR AXLE HOUSING WITH DIFFERENTIAL [003, 005] USED WITHOUT AUTOMATIC LOCKING DIFFERENTIAL (ASD)	001
176	A 124 350 07 74	<b>REPAIR KIT</b> REAR AXLE HOUSING WITH DIFFERENTIAL [004] ONLY USED WITH AUTOMATIC LOCKING DIFFERENTIAL (A S D)	001