



TO: ALL MERCEDES-BENZ PASSENGER CAR DEALERS

DATE: November 1996

REF. NO. MBNA 58/92

SUBJECT: NEW TIMING CHAIN TOOLS FOR DIESEL AND GASOLINE ENGINES

A new timing chain with a pressed on center link plate as part of the connecting link has been phased into production on the diesel engines.

See S.I. MBNA 05/95, for additional information regarding the new timing chain.

⚠ IMPORTANT!

- . Only the new modified timing chain is available as a spare part for diesel engines 601, 602, 603 and 606.
- . Prior to replacing the timing chain, review the timing chain replacement procedure as described in:
SMS, Engine 601, 602, 603; Mechanical III, Job No. 05-320.
SMS, Engine 604, 605, 606; Mechanical II, Job No. AR05.10-7601HA.

It is important that the center link plate of the connecting link be properly positioned when pressing the connecting link together during its final installation on the timing chain. For that reason, it is critical that the Special Tools described in this Service Information are used.

Additionally, the following Special Tools are considered temporary assembly aids and **must be removed after use**:

- . Threading link (temporary), Special Tool 602 589 02 40 00
- . Assembly link (temporary), Special Tool 602 589 02 63 00

For gasoline engines, when replacing the single and double row timing chains, the following special tools are required:

Link removal tool, Special Tool 602 589 02 33 00

Mandrel, link remover, Special Tool 602 589 05 63 00

Link removal pins, Special Tool 602 589 05 63 01

Swaging jaws, Special Tool 103 589 01 63 00

Note:

The following installation and riveting of timing chain procedure refers specifically to diesel engines 601, 602, 603, 604, 605 and 606. The procedure for gasoline engines is similar, please refer to the appropriate SMS Job No. before beginning the replacement of the timing chain.

INSTALLATION AND RIVETING OF TIMING CHAIN

Procedure

1. Remove Visco fan.
(see SMS, models 201, 124 and 140: Engines 601, 602, 603, Mechanical IV, Job No. 20-312).
(see SMS, models 124, 210: Engines 604, 605, 606, Mechanical II, Job No. AR20.40-5660HB).
2. Remove timing chain tensioner.
(see SMS, models 201, 124 and 140: Engines 601, 602, 603, Mechanical III, Job No. 05-310).
(see SMS, models 124, 210: Engines 604, 605, 606, Mechanical II, Job No. AR05.10-7800HA).
3. Disconnect and partially unscrew all glow plugs.
4. Remove valve cover.

Separating timing chain

5. Attach retainer (01, Figure 1) Special Tool 602 589 01 40 00 on engines 601 - 603 or Special Tool 602 589 00 40 00 on engines 604 - 606, to cylinder head with bolts as shown (arrows, Figure 1).
6. Cover exposed timing chain case with a clean shop towel.

As shown on engines 601 to 603

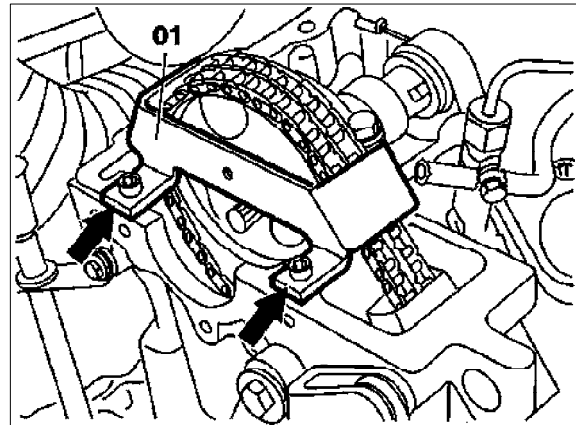

Figure 1

P05.10-0262-01

7. Install link remover mandrel (02, Figure 2) Special Tool 602 589 04 63 00 along with link removal pin, Special Tool 602 589 04 63 01 into link removal tool (03, Figure 2) Special Tool 602 589 02 33 00.
8. Lay above assembled link removal tool (03) onto the timing chain (Figure 2) and contact the leading link pin (Figure 3)
9. Using a wrench, turn link remover mandrel (02) in towards the timing chain until contact is made with the timing chain link plate (Figure 2).
10. Continue by turning mandrel (02a) (with link removal pin) (Figure 2) to press out the timing chain leading link pin from the old timing chain (Figure 3).

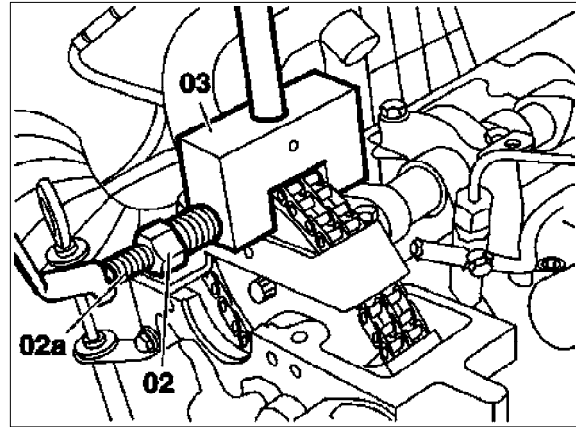

Figure 2

U05.10-0263-01

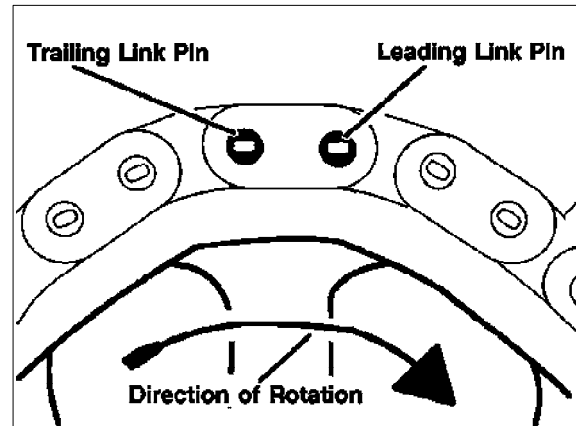

Figure 3

U05.10-0213-01

11. Unscrew link remover mandrel (02) and then remove link removal tool (03) from old timing chain (Figure 4). The timing chain is now separated.
12. Remove pressed out timing chain link pin (1) from link removal tool (03) (Figure 4).

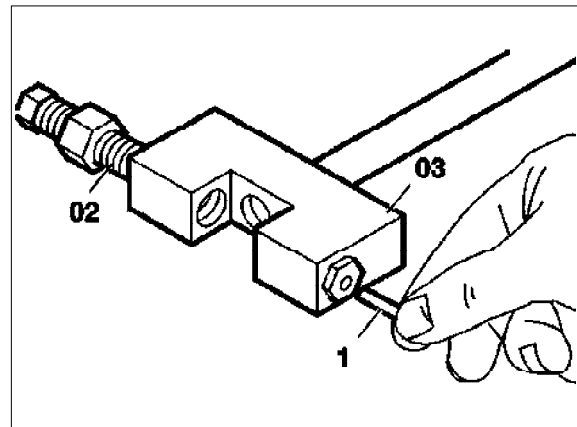

Figure 4

P05.10-0271-01

Installing new timing chain

13. Connect new timing chain (5, Figure 5) to the old timing chain (4, Figure 5) using the suitable threading link (04) from Special Tool 602 589 02 40 00.
14. Using a ratchet and socket on the crankshaft, carefully turn engine in direction of rotation, thereby rolling in the new chain (5, Figure 5) onto all the sprockets (in place of the old timing chain) while removing the old chain at the same time.

⚠ IMPORTANT!

Do not rotate engine backwards.

Apply pulling tension on old timing chain while feeding in new timing chain to ensure new timing chain properly engages all sprockets.

Retainers (602 589 01 40 00 and 604 589 00 40 00) prevent the timing chain from jumping from cam sprocket, thus eliminating the assistance of a second technician when feeding in the timing chain.

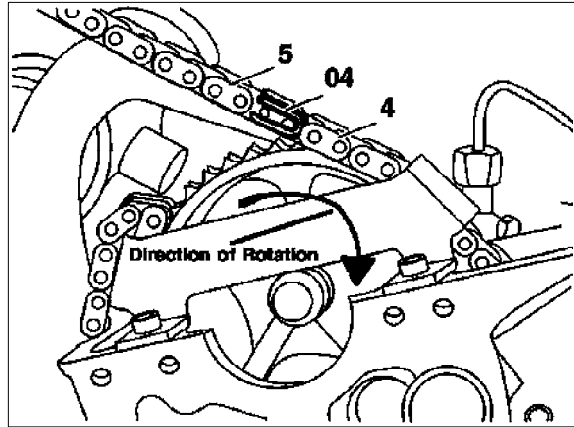

Figure 5

U05.10-0268-01

15. Disconnect old timing chain (4) from new timing chain (5) when the threading link (04) has reached the top of the camshaft sprocket (Figure 6). Remove and discard old timing chain.

⚠ IMPORTANT!

Threading link (04), Special Tool 602 589 02 40 00 is considered a temporary assembly aid only and **must be removed after use**.

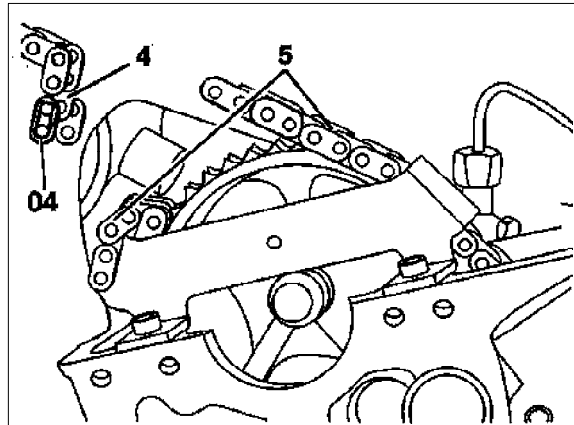

Figure 6

U05.10-0268-02

Riveting new timing chain connecting link

16. Connect the two timing chain ends (5, Figure 7) using the assembly link, Special Tool 602 589 02 63 00 (05, Figure 7) and also from the **new** timing chain insert the **new** connecting link center link plate (2, Figure 7).

⚠ IMPORTANT!

Insert assembly link (05) **as shown**, since it will be pushed back out by the link assembly tool when **new** timing chain connecting link is installed in step 20.

The assembly link (05), Special Tool 602 589 02 63 00 is considered a temporary assembly aid only and **must be removed after use**.

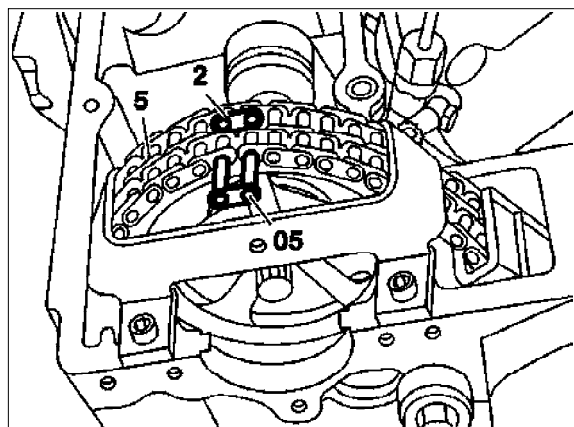

Figure 7

P05.10-0266-01

17. Attach swaging jaws (F5 and D9, Figure 8), Special Tool 602 589 02 63 00 into link assembly tool (06).
18. Insert new timing chain connecting link (3, Figure 8) into timing chain ends (5).
Observe direction of installation.
19. Lay link assembly tool (06) onto timing chain (5, Figure 8).
20. Press in new timing chain connecting link (3, Figure 8) by turning link assembly tool mandrel (07, Figure 8).

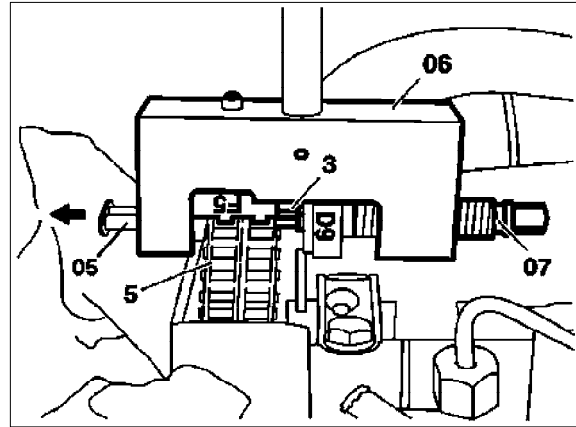

Figure 8

U05.10-0267-01

NOTE:

Assembly link (05) will be pushed out in forward direction (arrow, Figure 8), when pressing in new timing chain connecting link (3, Figure 8).

⚠ IMPORTANT!

The assembly link (05) is considered a temporary assembly aid only and **must be removed after use**.

21. Remove link assembly tool from timing chain.

22. Attach riveting inserts (D8 and F1) into link assembly tool (06, Figure 9).
23. Insert outer connecting link plate into link assembly tool (06). Outer connecting link plate will be held in place magnetically by link assembly tool. Press outer connecting link plate onto timing chain using mandrel.
24. In order to rivet the timing chain connecting link pins, rotate swaging jaw (D8, Figure 9). Then by turning mandrel carefully rivet the timing chain connecting link pins.

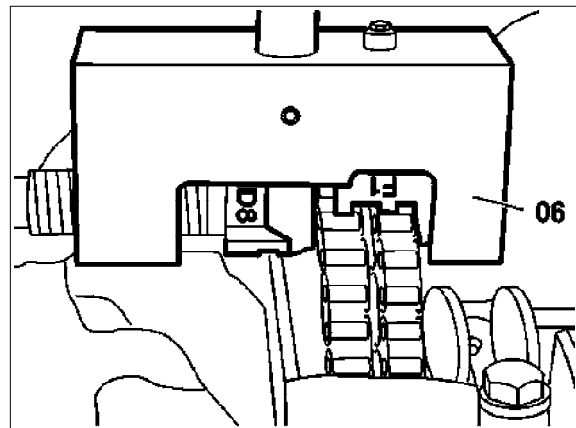

Figure 9

P05.10-0265-01

25. Carefully inspect riveted connecting link pins (arrows Figure 10). If necessary re-rivet pins by repeating step 24 again.
26. Carefully rotate engine by hand to verify camshaft timing. If necessary adjust camshaft timing and injection pump timing.
27. Reinstall timing chain tensioner.
28. Reinstall visco fan.
29. Tighten all glow plugs and reconnect wire harness.
30. Reinstall valve cover.

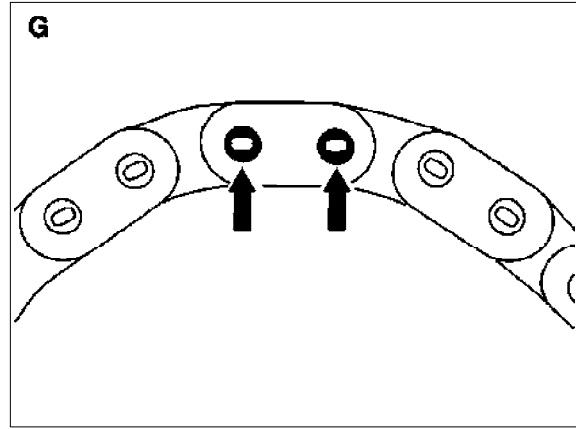

Figure 10

P05.10-0213-01

Special Tools



602 589 00 98 00

Case (without tools)

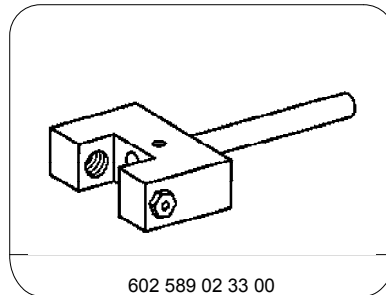

602 589 02 33 00

Link Removal Tool
for Diesel/Gasoline Engines

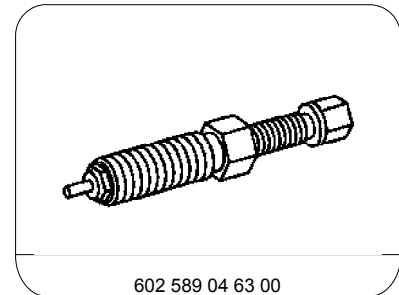

602 589 04 63 00

Mandrel, Link Remover
for Diesel Engines

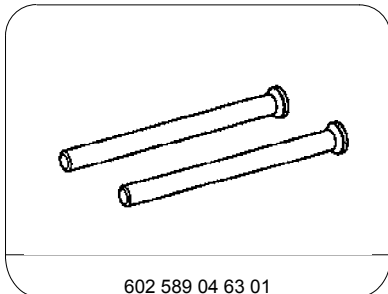

602 589 04 63 01

Link Removal Pins
for Diesel Engines
(wear item-replaceable set)

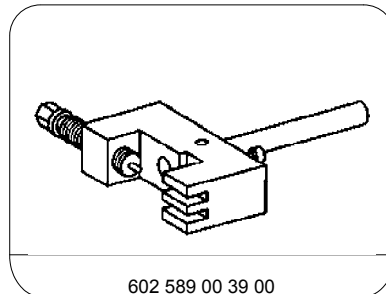

602 589 00 39 00

Link Assembly Tool
for Diesel/Gasoline Engines

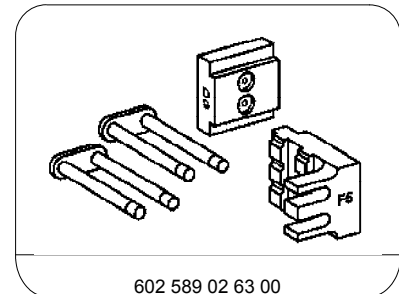

602 589 02 63 00

Assembly Link (temporary)
for Diesel/Gasoline Engines
and Swaging Jaws
for Diesel Engines

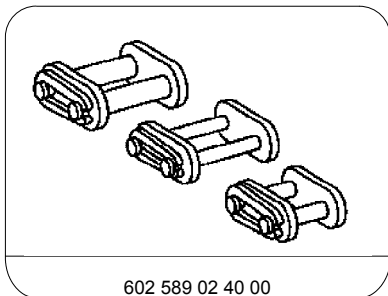

602 589 02 40 00

Threading Link Set (temporary)
for Diesel/Gasoline Engines

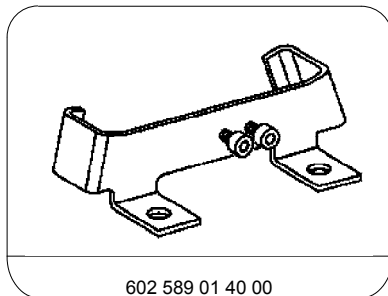

602 589 01 40 00

Retainer

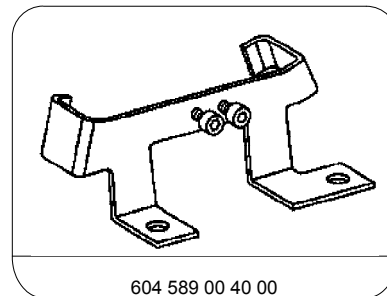

604 589 00 40 00

Retainer

Special Tools (continued)

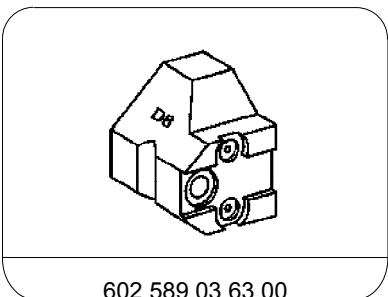

602 589 03 63 00

Swaging jaw
for Diesel Engines

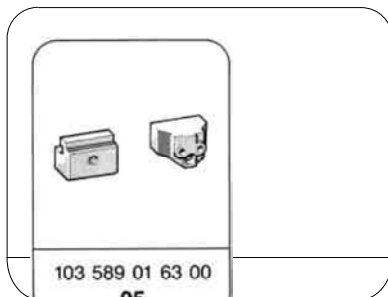

103 589 01 63 00

05
Swaging jaws
for Gasoline Engines

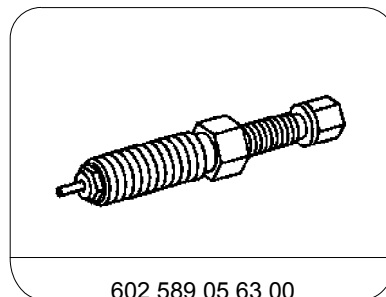

602 589 05 63 00

Mandrel, Link Remover
for Gasoline Engines

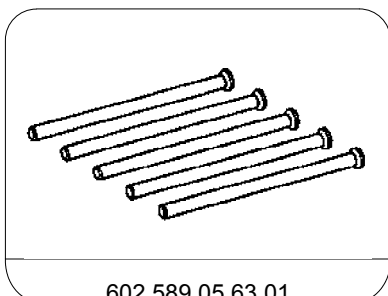

602 589 05 63 01

Link Removal Pins
for Gasoline Engines
(wear item-replaceable set)

Special Tools

Description	Part Number	Dealer price 4) (\$)
Case	602 589 00 98 00	24.00
Link removal tool 2)	602 589 02 33 00	186.00
Mandrel, link remover 1)	602 589 04 63 00	98.00
Link removal pins 1)	602 589 04 63 01	40.00
Link assembly tool (basic) 2)	602 589 00 39 00	123.00
Assembly link (temporary) 2) and swaging jaws 1)	602 589 02 63 00	69.00
Threading link (temporary) 2)	602 589 02 40 00	29.50
Retainer	602 589 01 40 00	18.50
Retainer	604 589 00 40 00	18.50
Swaging jaw 1)	602 589 03 63 00	100.00
Mandrel, link remover 3)	602 589 05 63 00	98.00

Link removal pins 3)	602 589 05 63 01	32.50
Swaging jaws 3)	103 589 01 63 00	91.00

- 1) Applicable to diesel engine only.
- 2) Applicable to both diesel and gasoline engines.
- 3) Applicable to gasoline engines only.
- 4) Price at time of publishing of S.I., subject to change without notice.